

# Nodak Electric Cooperative Technical Requirements



Distributed Energy Resource Technical  
Requirements for Systems Less than 10 MW.



**CONFIDENTIAL, COPYRIGHTED, AND PROPRIETARY**

This document was created for Burke-Divide Electric Cooperative Inc., Cass County Electric Cooperative Inc., Capital Electric Cooperative Inc., McLean Electric Cooperative Inc., Nodak Electric Cooperative Inc., North Central Electric Cooperative Inc. and Northern Plains Electric Cooperative Inc. Unauthorized reproduction of this information is strictly prohibited.

Copyright 2022 STAR Energy Services LLC

**STAR ENERGY SERVICES LLC SHALL NOT BE RESPONSIBLE FOR ANY DIRECT, INDIRECT, INCIDENTAL, OR CONSEQUENTIAL DAMAGES (INCLUDING LEGAL FEES AND COURT COSTS) ARISING OUT OF OR CONNECTED IN ANY WAY TO THE UNAUTHORIZED USE, MODIFICATION, OR APPLICATION OF THIS DOCUMENT OR THE PROPRIETARY INFORMATION, METHODS, AND SPECIFICATIONS SET FORTH IN THIS DOCUMENT, WHETHER IN WHOLE OR IN PART.**

## Contents

<b>1. Introduction</b>	<b>7</b>
1.1. General	7
1.2. Applicability	7
1.3. Solar Systems Less than 20kW	7
1.4. System Operation Type	8
1.5. Conventional Word Usage	8
1.6. Transition Period	8
<b>2. Abbreviations</b>	<b>8</b>
2.1. Abbreviations	8
<b>3. Glossary</b>	<b>8</b>
<b>4. Performance Categories</b>	<b>15</b>
<b>5. Reactive Power Capability and Voltage/Power Control Performance</b>	<b>15</b>
5.1. General	15
5.2. Constant Power Factor Mode <sup>h</sup>	16
5.3. Voltage and Reactive Power Control (Volt-Var)	16
<b>6. Response to Abnormal Conditions</b>	<b>16</b>
6.1. Introduction	16
6.2. Voltage Ride-Through and Tripping <sup>h</sup>	17
6.3. Frequency Ride-Through and Tripping <sup>h</sup>	17
6.4. Exceptions	17
<b>7. Protection Requirements</b>	<b>18</b>
7.1. Introduction	18
7.2. Requirement of Utility AC Disconnect <sup>h</sup>	18
7.2.1. Physical Requirements	18
7.2.2. Location of Utility AC Disconnect	19
7.3. Protection Coordination <sup>h</sup>	19
7.3.1. Secondary Services	19
7.3.2. Primary Services	19
7.3.3. Coordination with Distribution System Automatic Reclosing Schemes	19

7.4.	Grounded Wye-Wye Protection Requirements.....	20
7.4.1.	General Relay Information.....	20
7.4.2.	Non-Certified Inverters.....	20
7.4.3.	Relaying.....	20
7.4.4.	DC Power for Protection Devices.....	21
7.5.	Response to Faults and Open Phase Conditions <sup>h</sup> .....	21
7.5.1.	Open-Phase Detection.....	21
7.6.	Single-phase on Multiphase Service.....	22
7.7.	Interconnection Transformer Connections.....	22
7.7.1.	Wye-Wye Transformer Connections.....	22
7.7.2.	Wye-Delta Transformer Connections.....	22
7.7.3.	Delta-Wye Transformer Connections.....	22
7.8.	Grounding.....	23
7.8.1.	Requirement of Grounding Transformer.....	23
7.8.2.	Wye-Wye Interconnection.....	23
7.8.3.	Wye-Delta Interconnection.....	23
7.8.4.	Delta-Wye Interconnection.....	23
<b>8.</b>	<b>Metering<sup>h</sup>.....</b>	<b>23</b>
8.1.	DER Interconnection of Services with Sub-metering.....	23
8.2.	Metering Required for DER Installation.....	23
8.2.1.	Main Service Meter.....	24
8.2.2.	Production Meter.....	24
8.3.	Production Meter.....	24
8.3.1.	DER Systems with ESS.....	24
8.3.2.	Extended Parallel DER Interconnection.....	24
8.3.3.	All Other DER Interconnections.....	24
8.4.	Acceptable Metering.....	24
8.4.1.	Metering Sockets.....	25
8.4.2.	Locations and Accessibility.....	25
8.4.3.	Type of Metering Configurations.....	25
<b>9.</b>	<b>Signage and Labeling<sup>h</sup>.....</b>	<b>25</b>

9.1.	General Requirements .....	25
9.2.	Utility AC Disconnect.....	25
9.2.1.	Remotely Located Utility AC Disconnect.....	26
9.2.2.	Multiple Utility AC Disconnects .....	26
9.3.	Production Meter.....	26
<b>10.</b>	<b>Operations and Maintenance Requirements .....</b>	<b>26</b>
10.1.	Periodical Testing & Record Keeping .....	26
10.2.	Operations & Maintenance Agreements .....	27
10.3.	System Voltage .....	27
10.4.	Power Ramp Rates .....	28
10.5.	Enter Service .....	28
10.5.1.	DER Without Energy Storage Systems .....	29
10.5.2.	Energy Storage Systems .....	29
<b>11.</b>	<b>Power Control Systems – Limiting Capacity, Export and Import.....</b>	<b>29</b>
11.1.	General.....	29
11.2.	Power Control System Requirements.....	29
11.3.	Documentation .....	30
11.4.	Inadvertant Export .....	30
11.5.	Power Control Limited Capacity .....	30
11.6.	Power Control Limited Export and Limited Import.....	31
<b>12.</b>	<b>Interoperability .....</b>	<b>31</b>
12.1.	Overview .....	31
12.2.	Monitoring, Control and Information Exchange.....	33
12.3.	Sales to Parties Other Than Nodak Electric .....	33
12.4.	Level of Communicaiton Required.....	33
12.5.	Level of Monitoring and Control Required .....	34
12.6.	Cyber Security .....	34
12.6.1.	DER Physical and Front Panel Security.....	34
12.6.2.	DER Network Security .....	35
12.6.3.	Local DER Communication Interface Security.....	35
<b>13.</b>	<b>Energy Storage Systems.....</b>	<b>35</b>

13.1. Control Modes .....	35
13.2. Grid Support Functions .....	35
13.3. Common Modes of Operation .....	36
13.4. ESS Load Aspects.....	36
13.5. Enter Service .....	36
13.6. Modification to Control Modes .....	36
<b>14. Intentional Islanding.....</b>	<b>37</b>
<b>15. Test and Verification Requirements<sup>h</sup> .....</b>	<b>37</b>
15.1. Certified DER Systems.....	38
15.2. Non-Certified DER Systems.....	38
15.3. Documentation .....	38
15.3.1. Battery Documentation .....	38
15.4. Failure Protocol.....	39
15.5. Reverification and Periodic Test .....	39
15.6. Pre-Energization Testing – Interconnection Customer.....	39
15.7. Energization Testing Criteria .....	40
15.7.1. Installation Verification.....	40
15.7.2. Anti-Island Testing .....	41
15.7.3. Additional Onsite Testing.....	41
15.8. Modificaiton to Existing DER.....	41
<b>16. Sample Documentation for Tier I Applications<sup>h</sup> .....</b>	<b>42</b>
16.1 Introduction .....	42
16.2 One-line Diagram .....	42
16.3 Site Diagram.....	44
16.4 Testing Procedure .....	45
<b>17. References .....</b>	<b>46</b>
<b>18. Appendix A – Example Diagrams.....</b>	<b>49</b>
<b>19. Appendix B – Example DER Testing Procedure.....</b>	<b>53</b>
<b>20. Appendix C – Types of Interconnections.....</b>	<b>55</b>
<b>21. Appendix D – Relay Functions .....</b>	<b>65</b>
<b>22. Appendix E – Full and Partial Conformance Testing and Verification .....</b>	<b>68</b>

<b>23. Appendix F – IEEE 1547 – 2018 Settings</b> .....	<b>70</b>
23.1. Availability of Certified Equipment.....	70
23.2. Performance Category Assignment .....	70
23.2.1. Normal .....	70
23.2.2. Abnormal.....	70
23.3. Use of Default Parameters.....	71
23.4. Alternative Abnormal Operating Performance Categories .....	71
23.5. Advanced Setting for Power Control and Tripping .....	71
23.5.1. Voltage and Active Power Control (Volt-Watt).....	71
23.5.2. Voltage Ride-Through and Tripping .....	72
23.5.3. Frequency Ride-Through and Tripping .....	72
23.5.4. Exceptions .....	73

**Tables**

Table 1 - Origin of Defined Terms.....	9
Table 2 - Synchronous DER Response (shall trip) to Abnormal Voltages .....	16
Table 3 - DER Response (shall trip) to Abnormal Voltages for Inverter-based and Synchronous DER.....	17
Table 4 - DER Response (shall trip) to Abnormal Frequencies .....	17
Table 5 - DER Enter Service Criteria Ranges .....	28
Table 6 - Monitoring and Control Requirements for DER Systems .....	33
Table 7 - Summary of Relaying Requirements.....	67
Table 8 - Normal Performance Category Assignment .....	70
Table 9 - Voltage-Active Power Setting for Category A and Category B DER .....	71
Table 10 - DER Response (shall trip) to Abnormal Voltages for DER of Abnormal Operating Performance Category I .....	72
Table 11 - DER Response (shall trip) to Abnormal Voltages for DER of Abnormal Operating performance Category II .....	72
Table 12 - DER Response (shall trip) to Abnormal Frequencies for DER of Abnormal Operating Performance Category I, Category II and Category III .....	72
Table 13 - Rate of Change Frequency (ROCOF) Ride-Through Requirements for DER of Abnormal Operating Performance Category I and Category II.....	73
Table 14 - Rate of Change Frequency (ROCOF) Ride-Through Requirements for DER of Abnormal Operating Performance Category I and Category II.....	73



**Figures**

Figure 1 - Example Simplified One-Line Diagram.....43

Figure 2 - Sample Simplified Site Diagram .....44

Figure 3 - Example of Typical One-line Diagram of Solar DER Less than 20 kW .....49

Figure 4 - Example One-Line of Solar and ESS with a Common Inverter Less than 20 kW .....50

Figure 5 - Example One-Line of Solar and ESS with Separate Inverters Less than 20 kW .....51

Figure 6 - Example Placard .....52

Figure 7 - Open Transition (Break-Before-Make) Interconnection.....56

Figure 8 - Limited Quick Closed Transition (Make-Before-Break) Interconnection .....58

Figure 9 - Closed Transition Limited Parallel Interconnection.....60

Figure 10 - Extended Parallel Interconnection .....62

Figure 11 - Inverter-based Interconnection.....64

Figure 12 - Test and Verification Required Steps for RPA at PoC .....69

Figure 13 - Test and Verification Required Steps for RPA at PCC .....69

**Revision History**

Date	Version	Effective Date	Comments
	1.0	8/1/2022	Initial Date

# 1. Introduction

## 1.1. General

Nodak Electric Cooperative currently has interconnection process standards in effect to address the interconnection of distributed energy resources (DER) to the distribution grid. The Nodak Electric Cooperative Distributed Energy Resources Interconnection Process (Interconnection Process) applies to any DER no larger than 10-megawatt (MW) AC interconnecting to and operating in parallel with Nodak Electric Cooperative's distribution system in North Dakota. This document provides the Technical Requirements that shall be followed when interconnecting to Nodak Electric's system.

The Technical Requirement document is expected to be updated on a regular basis as DER technology and interconnection standards change. Interconnection Customers should confirm they are using the latest Technical Requirement version when designing their DER system.

Substantial changes to existing DER systems, such as capacity additions or inverter changes, are required to be compliant with the latest version of the Technical Requirement document.

## 1.2. Applicability

This document is designed to provide technical requirements for renewable, storage and fossil fuel DER systems specific to Nodak Electric. The wide-ranging type of DER systems addressed in this document at times may be classified by their certification, or lack thereof, to IEEE 1547-2018. In other locations in the Technical Requirements, the DER system may be classified as how the DER system operates with the Distribution System (also known as the utility's distribution system.) DER system size will affect the type of metering, monitoring and control required by Nodak Electric.

## 1.3. Solar Systems Less than 20kW

The majority of the DER interconnection applications Nodak Electric receives are sized less than 20kW and are solar systems with certified inverters. While the entire Technical Requirements document applies to all DER systems, solar systems sized less than 20kW should focus on meeting the requirements of the following sections:

- Section 5.2 – Constant Power Factor Mode
- Section 6.2 and 6.3 – Response to Abnormal Conditions
- Section 7.2, 7.3 and 7.5 – Protection Requirements
- Section 8 – Metering Requirements
- Section 9 – Signage and Labeling
- Section 15 – Test and Verification Requirement
- Section 16 – Sample Documentation for Tier I Applications

These sections have been identified by a **h** at the section header.

#### 1.4. System Operation Type

The Technical Requirements address different types of DER systems by the way the DER system operates with the Distribution System. Additional information on the different types is available in Section 20.

#### 1.5. Conventional Word Usage

Throughout this document, the word *shall* is used to indicate a mandatory requirement. The word *should* is used to indicate a recommendation. The word *may* is used to indicate a permissible action. The word *can* is used for statements of capability and possibility.

#### 1.6. Transition Period

All requirements of the Technical Requirements are immediately applicable unless requiring equipment that conforms with IEEE 1547-2018 advanced functionalities. At such time certified equipment first becomes available, Nodak Electric and DER Owner may mutually agree to utilize the certified equipment and functionalities in conformance with the requirements of IEEE 1547-2018. Additional details regarding technical requirements Nodak Electric may have with advanced functionalities can be viewed in Section 23.

### 2. Abbreviations

#### 2.1. Abbreviations

<b>AGIR</b>	Authority Governing Interconnection Requirements
<b>Area EPS Operator</b>	The utility that operates the distribution system. In this document the Area EPS Operator is Nodak Electric Cooperative.
<b>BPS</b>	Bulk Power System
<b>DER</b>	Distributed Energy Resource
<b>EPS</b>	Electric Power System
<b>ESS</b>	Energy Storage System
<b>PoC</b>	Point of Distributed Energy Resource Connection
<b>PCC</b>	Point of Common Coupling
<b>RPA</b>	Reference Point of Applicability
<b>RTO</b>	Regional Transmission Operator
<b>TPS</b>	Transmission Power System

### 3. Glossary

The definitions of terms used in this document are consistent with the IEEE 1547, IEEE 1547.1, and Cooperative's Interconnection Process for Distributed Energy Resources definitions, to the extent possible.

The origins of definitions are noted below in Table 1. The associated symbols are shown as a superscript to each term in order to denote the document from which the definition originates. For the purpose of denoting origin, the definition notes are to be considered part of the definition unless otherwise denoted with a separate symbol.

Table 1 - Origin of Defined Terms

Document of origin for definition	
IEEE 1547-2018	X
Cooperative's DER Interconnection Process	Λ
Technical Standards Requirements	Γ
Other (additional footnote is shown to denote origin)	ϑ

**Abnormal Operating Performance Category** <sup>x</sup>: The grouping for a set of requirements that specify technical capabilities and settings for a DER under abnormal operating conditions, i.e., outside the *continuous operation* region.

**Area Electric Power System (Distribution System)** <sup>^</sup>: The electric power distribution system connected at the Point of Common Coupling.

**Area Electric Power System Operator (Nodak Electric)** <sup>^</sup>: An entity that owns, controls, or operates the electric power distribution systems that are used for the provision of electric service in North Dakota.

**Authority Governing Interconnection Requirements (AGIR)** <sup>x</sup>: A cognizant and responsible entity that defines, codifies, communicates, administers, and enforces the policies and procedures for allowing electrical interconnection of DER to the Distribution System. This may be a regulatory agency, public utility commission, municipality, cooperative Board of Directors, etc. The degree of AGIR involvement will vary in scope of application and level of enforcement across jurisdictional boundaries. This authority may be delegated by the cognizant and responsible entity to Nodak Electric or *bulk power system operator*.

NOTE—Decisions made by an authority governing interconnection requirements should consider various stakeholder interests, including but not limited to other consumers, Nodak Electric, DER operators, and bulk power system operator.

**Bulk Power System (BPS)** <sup>x</sup>: Any electric generation resources, transmission lines, interconnections with neighboring systems, and associated equipment.

NOTE <sup>o 1</sup> – The usage of BPS in this document is intended to be generally aligned with the NERC definition of bulk electric systems, which includes transmission facilities with rated voltages above 100 kV; generating units with individual nameplate ratings above 25 MVA with a common point of connection, a voltage at 100 kV or above; and generating plants with total capacity ratings above 75 MVA with a common point of connection at 100 kV and above. The term Transmission Power System is used to describe the remaining transmission facilities that are rated for voltages less than 100 kV.

**Cease to Energize** <sup>x</sup>: Cessation of active power delivery under steady state and transient

---

<sup>1</sup> The note associated with BPS is intended to be largely aligned with the NERC definition. This is intended to supplement the definition of IEEE 1547 to reduce confusion since the NERC definition is a subset of the IEEE 1547 definition. A new definition, Transmission Power System is introduced in the section to cover the remaining facilities (i.e. < 100 kV transmission lines).

conditions and limitation of reactive power exchange.

NOTE 1—This may lead to momentary cessation or trip.

NOTE 2—This does not necessarily imply, nor exclude, disconnection, isolation, or a trip.

NOTE 3—Limited reactive power exchange may continue as specified, e.g., through filter banks.

NOTE 4—Energy storage systems are allowed to continue charging but are allowed to cease from actively charging when the maximum state of charge (maximum stored energy) has been achieved.

**Certified Equipment** <sup>^</sup>: Certified equipment is equipment that has been tested by a national recognized lab meeting a specific standard. UL 1741 listing is a common form of DER inverter certification.

**Interconnection Agreement** <sup>^</sup>: The terms and conditions between Nodak Electric and Interconnection Customer (Parties).

**Interconnection Process** <sup>^</sup>: The Cass County Electric Cooperative Interconnection Process for Distributed Energy Resources which is the interconnection process for Nodak Electric.

**Continuous Operation** <sup>^</sup>: Exchange of current between the DER and an EPS within prescribed behavior while connected to the Distribution System and while the applicable voltage and the system frequency is within specified parameters.

**Continuous Operation Region** <sup>^</sup>: The performance operating region corresponding to *continuous operation*.

**Distributed Energy Resource (DER)** <sup>^</sup>: A source of electric power that is not directly connected to a bulk power system. DER includes both generators and energy storage technologies capable of exporting active power to an EPS. An interconnection system or a supplemental DER device that is necessary for compliance with this standard is part of a DER.

NOTE 1—Controllable loads used for demand response are not included in the definition of DER.

NOTE 2<sup>r</sup>— See Figure 2 in IEEE 1547-2018.

**Distributed Energy Resource Operator (DER Operator)** <sup>^</sup>: The entity responsible for operating and maintaining the distributed energy resource.

**Distributed Energy Resource Unit (DER Unit)** <sup>^</sup>: An individual DER device inside a group of DER that collectively forms a system.

**Electric Power System (EPS)** <sup>^</sup>: Facilities that deliver electric power to a load.

NOTE <sup>r</sup>—This may include generation units. See Figure 2 in IEEE 1547-2018.

**Energize** <sup>^</sup>: Active power outflow of the DER to an EPS under any conditions (e.g., steady state and transient).

**Energy Storage System (ESS)** <sup>r</sup>: An electric system that stores active power for later injection into the Local EPS or Distribution System.

**ESS Control Mode**<sup>r</sup>: The function that manages the real and reactive power flow from or to an ESS in response to certain parameters, (such as time, price signals, frequency or external signals, etc.)

**Enter Service**<sup>x</sup>: Begin operation of the DER with an energized Distribution System.

**Intentional Island**<sup>x</sup>: A planned electrical island that is capable of being energized by one or more Local EPSs. These (1) have DER(s) and load, (2) have the ability to disconnect from and to parallel with the Distribution System, (3) include one or more Local EPS(s), and (4) are intentionally planned.

NOTE—An intentional island may be an *intentional Distribution System island* or an *intentional Local EPS island* (also: “facility island”).

**Interconnection**<sup>x</sup>: The result of the process of adding DER to a Distribution System, whether directly or via intermediate Local EPS facilities.

**Interconnection Agreement**<sup>^</sup>: The terms and conditions between Nodak Electric and Interconnection Customer (Parties).

**Interconnection Customer**<sup>^</sup>: The person or entity, including Nodak Electric, whom will be the owner of the DER that proposes to interconnect a DER(s) with Nodak Electric’s Distribution System. The Interconnection Customer is responsible for ensuring the DER(s) is designed, operated and maintained in compliance with the Technical Requirements.

**Interconnection Facilities**<sup>^</sup> – Nodak Electric’s Interconnection Facilities and the Interconnection Customer’s Interconnection Facilities. Collectively, Interconnection Facilities include all facilities and equipment between the DER and the Point of Common Coupling, including any modification, additions or upgrades that are necessary to physically and electrically interconnect the DER to Nodak Electric’s System. Some examples of Customer Interconnection Facilities include: supplemental DER devices, inverters, and associated wiring and cables up to the Point of DER Connection. Some examples of Nodak Electric Interconnection Facilities include sole use facilities; such as, line extensions, controls, relays, switches, breakers, transformers and shall not include Distribution Upgrades or Network Upgrades.

**Interconnection System**<sup>x</sup>: The collection of all interconnection and interoperability equipment and functions, taken as a group, used to interconnect a DER to a Distribution System.

**Interface**<sup>x</sup>: An electrical or logical connection from one entity to another that supports one or more energy or data flows implemented with one or more power or data links.

**Interoperability**<sup>x</sup>: The capability of two or more networks, systems, devices, applications, or components to externally exchange and readily use information securely and effectively.

**Inverter**<sup>x</sup>: A machine, device, or system that changes direct-current power to alternating-current power.

NOTE<sup>r</sup> - While the classical definition of inverter originating from IEEE 1547 considers power flow in a single direction, the usage of the term in this document indicates potential for bi-directional capabilities. The machine, device, or system can change power from direct-current to alternating-current and the machines, devices, or systems may also have capabilities to change power from alternating-current to direct-current.

**Island**<sup>x</sup>: A condition in which a portion of a Distribution System is energized solely by one or more Local EPS through the associated PCCs while that portion of the Distribution System is electrically separated from the rest of the Distribution System on all phases to which the DER is connected. When an island exists, the DER energizing the island may be said to be “islanding.”

**Load**<sup>x</sup>: Devices and processes in a local EPS that use electrical energy for utilization, exclusive of devices or processes that store energy but can return some or all of the energy to the local Distribution System in the future.

**Local DER Communication Interface**<sup>x</sup>: A local interface capable of communicating to support the information exchange requirements specified in this standard for all applicable functions that are supported in the DER.

**Local Electric Power System (Local EPS)**<sup>x</sup>: An EPS contained entirely within a single premises or group of premises.

**Maintenance Requirements**<sup>o</sup>: The maintenance terms and conditions between Nodak Electric and Interconnection Customer (Parties).

**Material Modifications**<sup>^</sup>: A modification to machine data, equipment configuration or to the interconnection site of the DER at any time after receiving notification by Nodak Electric of a complete Interconnection Application that has a material impact on the cost, timing, or design of any Interconnection Facilities or Upgrades, or a material impact on the cost, timing or design of any Interconnection Application with a later Queue Position or the safety or reliability of the Distribution System.<sup>2</sup>

**Momentary Cessation**<sup>x</sup>: Temporarily *cease to energize* an EPS, while connected to the Distribution System, in response to a disturbance of the *applicable voltages* or the system frequency, with the capability of immediate Restore Output of operations when the applicable voltages and the system frequency returns to within defined ranges.

---

<sup>2</sup> A Material Modification shall include, but may not be limited to, a modification from the approved Interconnection Application that: (1) changes the physical location of the point of common coupling; such that it is likely to have an impact on technical review; (2) increases the nameplate rating or output characteristics of the Distributed Energy Resource; (3) changes or replaces generating equipment, such as generator(s), inverter(s), transformers, relaying, controls, etc., and substitutes equipment that is not like-kind substitution in certification, size, ratings, impedances, efficiencies or capabilities of the equipment; (4) changes transformer connection(s) or grounding; and/or (5) changes to a certified inverter with different specifications or different inverter control settings or configuration. A Material Modification shall not include a modification from the approved Interconnection Application that: (1) changes the ownership of a Distributed Energy Resource; (2) changes the address of the Distributed Energy Resource, so long as the physical point of common coupling remains the same; (3) changes or replaces generating equipment such as generator(s), inverter(s), solar panel(s), transformers, relaying, controls, etc. and substitutes equipment that is a like-kind substitution in certification, size, ratings, impedances, efficiencies or capabilities of the equipment; and/or (4) increases the DC/AC ratio but does not increase the maximum AC output capability of the Distributed Energy Resource in a way that is likely to have an impact on technical review.

**Nameplate Ratings**<sup>x</sup>: nominal voltage (V), current (A), maximum active power (kW), apparent power (kVA), and reactive power (kVAR) at which a DER is capable of sustained operation.

NOTE—For Local EPS with multiple DER units, the aggregate DER nameplate rating is equal to the sum of all DERs nameplate rating in the Local EPS, not including aggregate capacity limiting mechanisms such as coincidence factors, plant controller limits, etc., that may be applicable for specific cases.

**Normal Operating Performance Category**<sup>x</sup>: The grouping for a set of requirements that specify technical capabilities and settings for DER under normal operating conditions, i.e., inside the *continuous operation* region.

**Non-export, Non-exporting**<sup>r</sup>: When the DER is sized and designed such that the DER output is used for host load only and is designed and operated to prevent the transfer of electrical energy from the DER to a Distribution System or TPS.

**Operating Requirements**<sup>^</sup>: Any operating and technical requirements that may be applicable due to the Transmission Provider's technical requirements or these Technical Requirements, including those set forth in the Interconnection Agreement.

**Parallel Operation**<sup>r</sup>: a source operated in parallel with the grid when it is connected to the distribution grid and can supply energy to the consumer simultaneously with the Distribution System supply of energy.

**Permissive Operation**: Operating mode where the DER performs ride-through either in *mandatory operation* or in *momentary cessation*, in response to a disturbance of the *applicable voltages* or the system frequency.

**Permissive Operation Region**: The performance operating region corresponding to permissive operation.

**Point of Common Coupling (PCC)**<sup>x</sup>: The point of connection between the Distribution System and the Local EPS.

NOTE 1— See Figure 2 in IEEE 1547.

NOTE 2—Equivalent, in most cases, to "service point" as specified in the National Electrical Code™ and the National Electrical Safety Code™.

**Point of Distributed Energy Resources Connection (point of DER connection–PoC)**<sup>x</sup>: The point where a DER unit is electrically connected in a Local EPS and meets the requirements of this standard exclusive of any load present in the respective part of the Local EPS.

NOTE 1—See Figure 2 in IEEE 1547.

NOTE 2—For (a) DER unit(s) that are not self-sufficient to meet the requirements without (a) supplemental DER device(s), the point of DER connection is the point where the requirements of this standard are met by DER (b) device(s) in conjunction with (c) supplemental DER device(s) exclusive of any load present in the respective part of the Local EPS.

**Power Control**<sup>r</sup>: System that controls the output (production or discharging) and input (charging) of one or more DER in order to limit output, input, export and/or import.



**Range of Allowable Settings**<sup>x</sup>: The range within which settings may be adjusted to values other than the specified default settings.

**Reference Point of Applicability (RPA)**<sup>x</sup>: The location where the interconnection and interoperability performance requirements specified in this standard apply.

**Regional Transmission Operator (RTO)**<sup>r</sup>: The functional entity that maintains the real-time operating reliability of the bulk electric power within a reliability coordinator area.

**Restore Output**<sup>x</sup>: Return operation of the DER to the state prior to the abnormal excursion of voltage or frequency that resulted in a ride-through operation of the DER.

**Return to Service**<sup>x</sup>: Enter service following recovery from a trip.

**Ride-Through**<sup>x</sup>: Ability to withstand voltage or frequency disturbances inside defined limits and to continue operating as specified.

**Secondary Network**<sup>r</sup>: An AC distribution system where the low-voltage of the distribution transformers are connected to a common network for supplying electricity directly to consumers. There are two types of secondary networks: grid networks and spot networks.

**Supplemental DER Device**<sup>x</sup>: Any equipment that is used to obtain compliance with some or all of the interconnection requirements of this standard.

NOTE—Examples include capacitor banks, STATCOMs, harmonic filters that are not part of a DER unit, protection devices, plant controllers, etc.

**Technical Requirements**<sup>x</sup>: The term including all of the DER technical interconnection requirement documents for Nodak Electric.

**Transmission Power System<sup>r</sup> (TPS)**: Any transmission or generation facility that is not part of the bulk power system.

NOTE - In general, this is transmission facilities rated at voltages less than 100 kV; transmission generation units with power ratings less than 25 MVA; and generation plants with total capacity ratings less than 75 MVA.

**Trip**<sup>x</sup>: Inhibition of immediate return to service, which may involve disconnection.

NOTE—Trip executes or is subsequent to cessation of energization.

**Type Test**<sup>x</sup>: a test of one or more devices manufactured to a certain design to demonstrate, or provide information that can be used to verify, that the design meets the requirements specified in this standard.

## 4. Performance Categories

The IEEE 1547 standard provides options of performance categories for all DER technology. Performance categories describe minimum equipment capability and the required ranges of allowable settings for voltage regulation, reactive power performance and response to abnormal conditions.

Category A and B specify reactive power capability and voltage regulation performance requirements. Category B is intended for use where DER penetration is higher and where the DER power output is subject to frequent large variations. Category A and B assignment is specified by Nodak Electric.

Categories I, II, and III differentiate performance requirements for DER response to abnormal conditions. Category III is the highest capability and can inherently meet the ride-through requirements of the lower categories. In contrast, the voltage and frequency trip requirements of higher categories may not be met by lower categories as the range of allowable settings may be mutually exclusive.

- I. Category I encompasses minimum BPS essential needs.
- II. Category II coordinates with North American Electrical Reliability Corporation (NERC) PRC-024-2 with a modification to the voltage ride-through in order to account for characteristics of distribution load devices<sup>3</sup>.
- III. Category III covers all BPS reliability needs and also introduces ride-through requirements aimed at addressing high DER penetration integration issues such as power quality events and other abnormal system conditions which may arise from DER tripping in the Local EPS.

Since certified equipment is currently not readily available, Performance Categories are not enforced at this time. For additional information regarding Nodak Electric's intentions with Performance Categories, see Section 23.

## 5. Reactive Power Capability and Voltage/Power Control Performance

Nodak Electric is responsible for maintaining voltage within standard ANSI C84.1 Range A for normal operations. Depending on the Distribution System characteristics for the system serving the location of interconnection, an economic solution to mitigate high-voltage caused by DER may be to implement DER active power and reactive power control functions. The implementation of these functions can contribute to Nodak Electric's ability to operate the system in a safe and reliable manner as increasing levels of DER are deployed. The use of these functions can allow higher levels of DER deployment in an economic manner.

### 5.1. General

As defined by IEEE 1547 Clause 5.3.1, Nodak Electric specifies a reactive power control mode. The DER shall be capable of providing the necessary power factor to help mitigate the

<sup>3</sup> Fault Induced Delayed Voltage Recovery is the main load consideration. This situation arises where distribution loads that typically consume reactive power draw increased levels of reactive power due to a low voltage event. The additional reactive power consumption of the distribution loads leads to a slower rebound in voltage returning to nominal levels.

impact of the DER on the grid. This section provides the default and expected capabilities of a DER system on the Distribution System.

In the circumstance where a DER Operator’s production is being impacted by the Distribution System voltage, the DER Operator should notify Nodak Electric of the voltage concern<sup>4</sup>. Nodak Electric shall investigate the cause of abnormal voltage. If the abnormal voltage is originating from the Distribution System, Nodak Electric may need to modify equipment or settings. Nodak Electric may also need to work with other electric services to bring voltage within ANSI C84.1 Range A. If the abnormal voltage is originating from the DER Operator’s premise, the DER Operator is responsible for mitigating the root cause.

The default in IEEE 1547 is to disable voltage-active power function. This requirement may necessitate a settings change from the default settings that DER equipment may contain when shipped from a manufacturer.

## 5.2. Constant Power Factor Mode <sup>h</sup>

The voltage and reactive power control for a DER system will greatly depend on the size and location of the DER within the Distribution System. Nodak Electric expects that the DER system shall maintain a steady PF at the PCC. Nodak Electric’s default settings for power factor control shall be as shown in Table 2.

*Table 2 - Synchronous DER Response (shall trip) to Abnormal Voltages*

DER System (kVA AC)	Power Factor	Reactive Power Control
0 kVA to < 250 kVA	0.98	Absorbing Reactive Power
250 kVA to < 5 MVA	0.98*	Absorbing Reactive Power
5 MVA to 10 MVA	0.98*	Absorbing/Providing Active Power

\*Systems shall be capable of being adjusted within the range of 0.95 to 1.0 PF

During normal operation of the DER system the power factor shall never be below 0.90 at the RPA.

## 5.3. Voltage and Reactive Power Control (Volt-Var)

Nodak Electric requires the settings for Volt-Var control to be disabled.

# 6. Response to Abnormal Conditions

## 6.1. Introduction

Until the Regional Transmission Operator determines the setting for mandatory tripping, all DER systems are required to disconnect from the Distribution System when the Distribution System experiences abnormal frequency or voltage to avoid unintentional islanding. All DER

<sup>4</sup> For example, DER with the PCC located near the substation with a high source voltage may require upward adjustment of the V<sub>1</sub> parameter to avoid significant production impacts.

systems shall trip for any abnormal voltage or abnormal frequency with clearing times as stated in the following sections.

## 6.2. Voltage Ride-Through and Tripping <sup>h</sup>

The DER shall trip for any abnormal voltage. Table 3 lists the maximum clearing time for the DER system upon the occurrence of abnormal voltage levels.

*Table 3 - DER Response (shall trip) to Abnormal Voltages for Inverter-based and Synchronous DER*

Shall Trip – Synchronous DER		
Shall Trip Function	Default Setting	
	Clearing time(s)	Voltage (p.u. of nominal voltage)
UV2	0.16	0.50
UV1	2.0	0.88
OV1	1.0	1.10
OV2	0.16	1.20

No advanced voltage ride through is allowed. Future technology and situations may allow DER operations to ride-through some voltage flickers and not require the DER system to go offline, however at this time all DER systems shall be required to disconnect and reconnect for all abnormal voltage occurrences.

## 6.3. Frequency Ride-Through and Tripping <sup>h</sup>

The DER shall conform to the ride-through requirements for the applicable Abnormal Operating Performance Category. The IEEE 1547 default parameters shall be implemented by the DER Operator for the applicable performance category. The RTO may provide guidance on mandatory ride-through capabilities.

*Table 4 - DER Response (shall trip) to Abnormal Frequencies*

Shall Trip Function	Default Setting	
	Clearing time(s)	Frequency (Hz)
UF1	0.16	59.3
OF1	0.16	60.5

## 6.4. Exceptions

DER systems designated by authority having jurisdiction as emergency, legally required, or critical operations power systems providing backup power to hospitals, fire stations or other emergency facilities as defined by applicable industry code, shall be exempt from the ride-through requirements of this section.

## 7. Protection Requirements

### 7.1. Introduction

Protective devices are required to permit safe and proper operation of the Distribution System while interconnected with DER systems. Examples of the protection requirements for different types of DER interconnections are shown in Appendix C. The figures in Appendix C are for typical installations and may not fit all possible configurations. The specific protection requirements for interconnection will depend upon the DER's size and type; the number of units; Distribution System configuration and characteristics; the operating modes of the DER; and the location of the proposed DER interconnection on the Distribution System.

The interconnection of a new DER facility to the Distribution System shall not degrade any of the existing Distribution System protection and control schemes nor lower the existing levels of safety and reliability to other entities interconnected as loads to the Distribution System.

The Interconnection Customer shall provide protective devices and systems to detect the voltage, frequency and harmonic levels as defined in the IEEE 1547 during periods when the DER is operated in parallel with the Distribution System. The Interconnection Customer shall be responsible for the purchase, installation, and maintenance of these devices.

### 7.2. Requirement of Utility AC Disconnect <sup>h</sup>

#### 7.2.1. Physical Requirements

A Utility AC Disconnect furnished by the Interconnection Customer is required on all DER systems to safely isolate the DER from the Distribution System. The disconnect shall:

- Provide a visible air-gap.
- Be an AC rated device, UL or National Electrical Manufacturers Association approved.
- Be manually operable by one person.
- Be lockable in the open position.
- Be sized for adequate ampere capacity.
- Be continuously readily accessible, with unescorted access to Nodak Electric's personnel.
- Does not require fasteners to be removed to access the disconnect handle.
- Be gang operated so that operation of one switch handle opens and closes all energized conductors simultaneously.
- Not interrupt neutral conductors.

The Utility AC Disconnect may be the same disconnecting means required by the NEC 690.13, 705.20 or 706.15 if the disconnect meets all the other Nodak Electric requirements listed in this section.

### 7.2.2. Location of Utility AC Disconnect

The Utility AC disconnect used by Nodak Electric to safely isolate the DER from the Distribution System shall be located within 10 feet of the revenue meter and installed at a minimum height of 3 feet from the ground. If the Utility AC Disconnect is proposed to not be located within 10 feet of the revenue meter, the proposed location will be identified on the site drawing submitted to Nodak Electric with the Interconnection Application.

Nodak Electric reserves the right to withhold approval for the placement of the Utility AC Disconnect in a location which is not within 10 feet of the revenue meter. If approved location is not located within 10 feet of the revenue meter, a permanently affixed placard meeting NEC requirements, as discussed in Section 9, shall be located at the revenue meter indicating the Utility AC Disconnect location. The placard shall achieve this with a mapped representation of the property, with the location of the AC disconnect denoted. The placard shall be made of a material that is of durable for outdoors conditions and resists fading from sunlight. An example of the placard is shown in Appendix A.

## 7.3. Protection Coordination <sup>h</sup>

### 7.3.1. Secondary Services

In general, overcurrent protection requirements shall meet the requirements of the NEC for DER interconnection that occur behind Nodak Electric's revenue meter. All electric services are required to have main service protection furnished by the Interconnection Customer immediately after the main service meter. Double-lugged meters shall have overcurrent interrupting protection on both sets of conductors immediately after the revenue meter.

### 7.3.2. Primary Services

The first protective device on the DER Interconnection Customer's side of the revenue meter shall coordinate with Nodak Electric's protective device. Protection coordination studies are required for interconnections to the primary system. The protection study shall be completed by the Interconnection Customer and reviewed and approved by Nodak Electric prior to interconnection and energization.

### 7.3.3. Coordination with Distribution System Automatic Reclosing Schemes

Nodak Electric may have automatic reclosing schemes designed into the Distribution System to attempt to prevent transient faults from becoming a long-term outage. The automatic reclosing scheme will de-energize a portion of the Distribution System and re-energize the same section of Distribution System in a short period of time, less than one second, often clearing the fault on the Distribution System.

Automatic reclosing on the Distribution System can potentially damage rotating DER generation, both synchronous and induction DER generators, operating in parallel with the Distribution System. The addition of DER shall not alter the standard auto restoration schemes designed in the Distribution System. The Interconnection

Customer is responsible for protecting the DER facility's equipment from damage due to the automatic or manual reclosing, faults or other disturbances on the Distribution System.

#### 7.4. Grounded Wye-Wye Protection Requirements

The following protection requirements are for grounded wye-wye DER system interconnections. Additional protection requirements may apply for DER systems which are not grounded wye-wye or do not utilize a grounded wye-wye transformer as part of the DER interconnection system design. Non-exporting DER systems that operate in parallel with the Distribution System have the same requirements as that of any other DER interconnection.

##### 7.4.1. General Relay Information

For DER systems which are smaller than 250kW and utilize a certified inverter(s) for interconnection, a Professional Electrical Engineer is not required to review, test and approve the protective functions or settings of the inverter. For all other DER systems to be interconnected with the Distribution System, the protective functions and relay setting shall be reviewed and approved by a Professional Electrical Engineer registered in the State of North Dakota.

Prior to energization or interconnection of the DER with the Distribution System, a copy of the proposed protective relay settings shall be supplied to Nodak Electric for review and approval. Nodak Electric shall review the protective relay settings to ensure proper coordination between the DER and the Distribution System. The proposed protective relay settings shall be provided to Nodak Electric with time allotted to allow for review, coordination, implementation and functional testing of the protective system including any requested modifications.

##### 7.4.2. Non-Certified Inverters

The use of inverters that have not been tested by a Nationally Recognized Testing Laboratory (NRTL) and certified to meet the UL 1741 performance requirements are not allowed by Nodak Electric as an acceptable design of the DER system.

##### 7.4.3. Relaying

All equipment providing relaying functions shall meet or exceed ANSI/IEEE Standards for protective relays, i.e., C37.90, C37.90.1 and C37.90.2.

Required relays that are not drawout cased relays shall have test plugs or test switches installed to permit field testing and maintenance of the relay without unwiring or disassembling the equipment.

Three-phase interconnections shall utilize three-phase power relays, which monitor all three phases of voltage and current, unless so noted in the Appendix C diagrams.

All protective relays must have DC power supplies powered by station class batteries and charging system. The battery system shall be equipped with a DC-undervoltage detection alarm or be monitored by a continuous monitoring facility.

For DER larger than 250kW, the DC voltage level must be provided to Nodak Electric's SCADA system. See Section 12 for further information.

All relays shall be equipped with setting limit ranges at least as wide as specified in IEEE 1547, and meet other requirements as specified in the Distribution System interconnection study. Setting limit ranges are not to be confused with the actual relay settings required for the proper operation of the installation. At a minimum, all protective systems shall meet the requirements established in IEEE 1547.

See Appendix D for specific information regarding the types of relaying.

#### 7.4.4. DC Power for Protection Devices

All relays and other devices which require external power to operate must be supplied by a DC battery system that can maintain power to the protective device for a minimum of 8 hours during a complete power outage. The DC battery charger shall be able to be powered by the DER if power from the Distribution System is lost. The DER shall be blocked from reconnecting to the Distribution System if the adequate DC power is not available to the protective devices.

The DC battery system shall be capable of monitoring and alarming for certain conditions related to voltage levels and charging ability. The DC battery system shall be monitored for DC voltage levels and have the capability of alarming if DC voltage reaches levels that cannot allow operation. The DC battery system shall also alarm if the battery charging system fails.

The alarms from the DC battery system shall be monitored by the Interconnection Customer. If the alarms are not monitored continuously, the alarm shall be audible or include a flashing light before complete loss of DC battery voltage.

### 7.5. Response to Faults and Open Phase Conditions <sup>h</sup>

The DER shall Cease to Energize and Trip for faults on the Distribution System. The DER shall detect and Cease to Energize and Trip all phases to which the DER is connected for an open phase condition occurring directly at the reference point of applicability. The requirement to Cease to Energize for a single-phase condition shall apply to both three-phase inverters and three-phase installations made up of single-phase inverters. As required by IEEE 1547, the DER shall detect and Cease to Energize and Trip for unintentional islands. When restoring output after Momentary Cessation, the Restore Output settings of the DER shall be coordinated with the Distribution System reclosing timing.

#### 7.5.1. Open-Phase Detection

For non-inverter-based DER, or inverter-based DER that opt not to use the onboard protective functions of the inverter for open-phase detection, either due to DER design configurations that render the detection method invalid or other reason, special consideration will need to be given to the methodology used to detect and trip for an open phase event.

Typical inverter-based configurations that require additional relaying include:



- Configurations with zig-zag or grounded wye-delta grounding banks.
- Configurations with delta windings on onsite transformers.

As required by IEEE 1547, all DER must detect open phase conditions at their RPA when their output is as low as 5% of their rated output, or, if not capable of producing apparent power at 5% of its rated output, at the lowest output the DER can continue producing apparent power.

Nodak Electric does not recommend a specific method for detecting an open phase condition.

## 7.6. Single-phase on Multiphase Service

The total nameplate rating for an individual single-phase inverter on a multi-phase system cannot exceed 20% of the distribution transformer rating that is supplying the service.

Multiple single-phase DER systems which are connecting to a multi-phase service to form a three-phase generation source, must provide protection to allow sensing and tripping of the entire DER system upon loss of a single individual phase.

DER systems which are connecting to an existing two-phase Open Delta-Wye or Open Wye-Delta secondary must be single-phase or the voltage of the service shall be converted to 120/208 or 277/480 volts.

## 7.7. Interconnection Transformer Connections

Interconnection Customer-owned transformers that are part of the DER system shall fall under one of the following connections.

### 7.7.1. Wye-Wye Transformer Connections

A Wye-Wye transformer is the preferred transformer connection. Both the primary and secondary of the transformer must be grounded. Note, this transformer connection is subjected to harmonics from the Distribution System and the DER must be designed to limit the harmonic output from the DER system to below IEEE standard levels.

### 7.7.2. Wye-Delta Transformer Connections

The wye side of the transformer is required to be grounded. High side voltage monitoring to sense single-phase faults on the primary side of the transformer is required. All issues with zero sequence injections into the Distribution System from the Grounded Wye winding shall be addressed. Documentation is required to be provided to Nodak Electric for review.

### 7.7.3. Delta-Wye Transformer Connections

This transformer configuration is not allowed for interconnection of a DER system.

## 7.8. Grounding

For Interconnection Customers providing transformers that are part of the DER system, the transformer grounding shall properly interconnect with the grounding of the Distribution System.

### 7.8.1. Requirement of Grounding Transformer

Grounding transformers are not required by Nodak Electric. It is the Interconnection Customers responsibility to design the DER system so not to detrimentally affect power quality to the surrounding area.

### 7.8.2. Wye-Wye Interconnection

For Wye-Wye transformer configurations, both the primary and secondary side of the transformer shall be grounded. The DER must also include an appropriately sized ground bank or the generator's neutral must be adequately grounded.

### 7.8.3. Wye-Delta Interconnection

For Wye-Delta transformer configurations the wye side is required to be grounded.

### 7.8.4. Delta-Wye Interconnection

Delta-Wye transformer configurations are not allowed by Nodak Electric for DER systems interconnected to the Distribution System.

## 8. Metering<sup>h</sup>

The metering requirement for each DER system will depend on the DER size, location, interconnection type and application rate schedules. It is the Interconnection Customer's responsibility to provide metering sockets as applicable. Nodak Electric will provide the meter(s), CTs and VTs, unless the DER sales are to a third party. For DER with sales to a third party, the Interconnection Customer shall be responsible for all metering costs incurred by Nodak Electric.

### 8.1. DER Interconnection of Services with Sub-metering

Nodak Electric does not allow for DER systems of the extended parallel type to be on an electric service where subtractive metering already exists. Consult with Nodak Electric of alternative options.

### 8.2. Metering Required for DER Installation

The metering required for DER system depends on the size and type of DER, the method of interconnection and applicable rate programs the DER may take part in. There may be unique installations which may require deviations from requirements listed in this document. Deviations from this specification will be documented in the Operating and Maintenance Requirements section of the Interconnection Agreement.

#### 8.2.1. Main Service Meter

The main service meter is located at the PCC, unless mutually agreed upon between Nodak Electric and Interconnection Customer<sup>5</sup>, and is the meter Nodak Electric shall use for billings purposes. This is commonly called a bidirectional meter.

#### 8.2.2. Production Meter

A production meter may be required by Nodak Electric and is located electrically at the PoC. This meter will monitor the power flow to and from the DER. The production meter may be used for incentive programs or standby calculations and provides Nodak Electric with necessary information to properly engineer a safe and reliable grid. Nodak Electric does require a production meter for specific DER installation as listed in 8.3.

### 8.3. Production Meter

#### 8.3.1. DER Systems with ESS

There are multiple variations of DER systems that include ESS. Depending on the configuration, non-exporting DER systems that incorporate ESS may not need a production meter. Consult with Nodak Electric to determine the proper metering needs.

#### 8.3.2. Extended Parallel DER Interconnection

Nodak Electric requires the main meter at the PCC and a production meter at the PoC. Nodak Electric will reprogram or replace the main service meter to be able to measure and record power flow in both directions. It is the cost responsibility of the Interconnection Customer for the metering Nodak Electric will install at the PoC. Nodak Electric will provide the meter to record production. For DER systems where the PCC and PoC are the same location, a single meter can perform both types of metering.

#### 8.3.3. All Other DER Interconnections

DER interconnections that are not extended parallel will need to confer with Nodak Electric to determine the appropriate metering needs.

### 8.4. Acceptable Metering

A brief list of metering specifications is listed in the following subsections. Variation from Nodak Electric requirements will need to be mutually agreed to by Nodak Electric and documented in the Operating and Maintenance Requirements section of the Interconnection Agreement.

---

<sup>5</sup> If the main meter is not located at the PCC, the Interconnection Agreement shall document the agreed upon losses and billing will be adjusted accordingly.

#### 8.4.1. Metering Sockets

The interconnection owner is responsible for purchasing and installing a meter socket that meets the following requirements and is appropriate for the service connect.

- Meter sockets must be UL (Underwriters Laboratories) or ARL (Applied Research Laboratories) approved.
- All metering for a single service must be grouped in a 10-foot area.
- All self-contained meter sockets must be a bypass type socket with a manually operated lever bypass of 200-amp minimum size.

#### 8.4.2. Locations and Accessibility

The meter socket shall be installed in a location that meets the following specifications:

- The center of the meter socket shall be located at a height between 4 to 6 feet above the ground.
- Location and path to the meter socket must be continuously clear and free of hazards for anyone accessing the meter.
- Meter sockets must be a minimum of 3 feet away from a gas meter and 6 feet away from combustible storage.
- Meter sockets shall have unobstructed space of at least 3 feet in front and 1 foot to each side.

The specifications for meter socket location and accessibility shall be maintained for the life of the meter use. If changes cause the meter to no longer meet the stated specifications, the meter shall be moved to a new accessible location at the expense of the Interconnection Customer.

#### 8.4.3. Type of Metering Configurations

See Section 20 for expected metering configurations.

### 9. Signage and Labeling <sup>h</sup>

#### 9.1. General Requirements

All signage and labeling shall meet applicable NEC requirements including NEC 110.21 (B), 690.13 and 750.10.

#### 9.2. Utility AC Disconnect

The Utility AC disconnect shall be labeled as "UTILITY AC DISCONNECT." The Utility AC Disconnect shall be located within 10 feet of the main service meter. Nodak Electric and the Interconnection Customer may mutually agree to install the Utility AC Disconnect at a location greater than 10 feet from the main service meter.

#### 9.2.1. Remotely Located Utility AC Disconnect

If the Utility AC Disconnect is not located within 10 feet of the main service meter, a permanently affixed waterproof placard shall be located within 10 feet of the main service meter. The placard shall include a mapped representation of the property with the location of the Utility AC Disconnect clearly denoted. A copy of the proposed placard shall be submitted to Nodak Electric with the interconnection application.

#### 9.2.2. Multiple Utility AC Disconnects

If a single Utility AC Disconnect cannot be used to disconnect all DERs, all Utility AC disconnects should include numerical identification such as "UTILITY DER AC DISCONNECT 1 OF 2" or similar. The number of disconnects required to be operated to isolate the DER from the utility should be clear. A permanently affixed waterproof placard shall be located within 10 feet of the main service meter clearly indicating the number and locations of the multiple Utility AC Disconnects. A copy of the proposed placard shall be submitted to Nodak Electric with the interconnection application.

### 9.3. Production Meter

The production meter shall be labeled as "DER PRODUCTION METER" or similar. If there are multiple DER types present at a location the production meter shall indicate the type of DER behind the meter.

## 10. Operations and Maintenance Requirements

### 10.1. Periodical Testing & Record Keeping

The Interconnection Customer shall notify Nodak Electric prior to any of the following events occurring:

- Protection functions are being adjusted after the initial commissioning process.
- Functional software or firmware changes are being made on the DER.
- Any hardware component of the DER is being modified in the field or is being replaced or repaired with parts that are not substitutive components compliant with this standard.
- Protection settings are being changed after factory testing.

Prior to modifications to the DER triggering reverification, the Interconnection Customer shall notify Nodak Electric's interconnection coordinator, by emailing [info@utilitydomain.com](mailto:info@utilitydomain.com). The email should include details about the proposed modification and the DER contact to communicate with for additional information, if needed. Any of the above events may be cause for requiring reverification of the interconnection and interoperability requirements.

All interconnection-related protection and control systems shall be periodically tested and maintained, by the Interconnection Customer, at intervals specified by the manufacturer or system integrator and shall not exceed five years. Periodic test reports and a log of

Commented [KR1]: Customization here

inspections shall be maintained by the Interconnection Customer and made available to Nodak Electric upon request. Nodak Electric shall be notified prior to the testing of the protective and control systems to witness the testing if so desired. The testing procedure for re-test should be a functional test of the protection and control systems.

Nodak Electric requires any system that depends upon a battery for trip/protection power shall be checked and logged once per month for proper voltage. For DER systems with nameplate rating of 1,000kW or more, continuous monitoring of the DC battery voltage is required. Logging of all periodic inspection is recommended.

## 10.2. Operations & Maintenance Agreements

For DER systems that operate in parallel with a capacity 40 kW or greater alternating current, the Operating and Maintenance Requirements<sup>6</sup> section of the Interconnection Agreement is established. The Operating and Maintenance Requirements section of the Interconnection Agreement covers items that are necessary for the reliable operation of the Local EPS and Distribution System and are unique to each DER. The items included as Operating Requirements shall not be limited to the items shown on this list:

- i. Operational requirements, settings, and limits for DER when the Distribution System is in a normal condition
- ii. Operational requirements, settings, and limits when the Distribution System is in an abnormal condition due to maintenance, contingencies, or other system issues
- iii. Permitted and disallowed ESS Control Modes
- iv. BPS or TPS limitations and arrangements that could impact DER operation
- v. DER restoration of output or return to service settings and limitations
- vi. Response to control or communication failures
- vii. Performance category assignments (normal and abnormal)
- viii. Dispatch characteristics of DER
- ix. Notification process between Interconnection Customer and Nodak Electric
- x. Right of Access

The following is a list of typical items that may be included as Maintenance Requirements. The items included as Maintenance Requirements shall not be limited to the items included in this list:

- i. Routine maintenance requirements and definition of responsibilities
- ii. Material modification of the DER that may impact the Distribution System

## 10.3. System Voltage

Operation of the DER shall not cause the voltage at the PCC to go outside of ANSI Range A under normal operations. Operation of the DER that causes voltages to go outside the ANSI

---

<sup>6</sup> Attachment V of the Interconnection Agreement is the Operating and Maintenance Requirements for Nodak Electric's Distribution System Need to Support the Interconnection Customer's Need. This is referred to as the Operating and Maintenance Requirements in this document.

Range A voltage values may be cause for disconnection until the reason can be identified and corrected.

Any sudden voltage changes caused by the DER which adversely affect other interconnected entities to the Distribution System shall not be allowed. It is the DERs responsibility to resolve adverse voltage changes caused by the operation of their DER. Nodak Electric will work cooperatively with the DER to identify possible solutions.

#### 10.4. Power Ramp Rates

The ability for the Distribution System to respond to large changes in increasing or decreasing demand for energy depend upon the PCC with the Distribution System. The ratio of generation to load on the Distribution System correlates with the potential of voltage disturbances on the Distribution System as generation is abruptly added or removed from extended parallel operation with the Distribution System. In some cases, if the step change is large enough, Distribution System protection devices may operate under the assumption a fault has occurred with the abrupt change in voltage. The larger the amount of load or generation added or removed from the Distribution System, the greater the chance of creating operational problems for other entities interconnected on the Distribution System.

As part of the interconnection study, Nodak Electric will review the potential for step changes of 3% or greater in load or energy production that can create operational problems on the Distribution System. It is the Interconnection Customer's responsibility to review for potential Local EPS issue which may result from block changes in load or generation from the DER.

DER systems shall not cause the Distribution System voltage to be outside of ANSI Range A voltage levels. Block loading or off-loading of the DER generation that causes voltage step changes of 3% or greater on the Distribution System is not allowed.

#### 10.5. Enter Service

Enter Service is the period where the DER begins operation with an energized Distribution System. Enter Service may be part of daily operation of the DER or occur after a power outage on the Distribution System. The method the DER uses to Enter Service is important to the reliability and performance of the Local EPS and the Distribution System. All DER systems shall not energize and parallel with the Distribution System unless applicable voltage and system frequency are within the ranges specified in Table 5.

Table 5 - DER Enter Service Criteria Ranges

Enter Service Criteria		Default settings
Applicable voltage within range	Minimum Value	$\geq 0.917$ p.u.
	Maximum Value	$\leq 1.05$ p.u.
Frequency within range	Minimum Value	$\geq 59.3$ Hz
	Maximum value	$\leq 60.5$ Hz

DER shall be capable of delaying enter service by an intentional adjustable minimum delay when the Distribution System steady-state voltage and frequency are within the ranges

specified in Table 5. The adjustable range of the minimum intentional delay shall be 0 s to 300 s with a default minimum delay of 300 s.

#### 10.5.1. DER Without Energy Storage Systems

For DER that does not include ESS, possible methods which may be required include:

- The delay time for re-energization of the DER after an outage may be increased.
- The DER may be required to stagger the re-energization of inverters.
- Multiple transfer switches may be required to divide up the blocks of load transferred to the DER.

#### 10.5.2. Energy Storage Systems

ESS shall be set to an intentional delay of a minimum of 300 s, (5 minutes), before initiating recharging of the ESS. If possible, Nodak Electric would prefer the ESS ramp up the recharging level from 0 – 100% over the first ten-minute time period of initial recharging. ESS larger than 250kW may be required to have a specific intentional delay prior to enter service. The specific delay will be documented in the Operating and Maintenance Requirements section of the Interconnection Agreement.

## 11. Power Control Systems – Limiting Capacity, Export and Import

### 11.1. General

Power control systems are used to control the output from a DER system due to an external condition. For example, the output from a DER unit may be limited so that it does not export energy back into the Distribution System at the PCC. To accomplish this the power control system would sense the flow of energy at the PCC and relay that information back to the DER to limit DER output if there was any reverse energy flow at the PCC.

### 11.2. Power Control System Requirements

The power control system must be NRTL certified control system that meets the following requirements.

- Able to halt or reduce energy production within two seconds after either the period of continuous export to the Distribution System exceeds 30 seconds or the level of export exceeds the lesser of 100kW or 10% of the DER nameplate rating.
- Able to monitor the total energy exported.
- Able to self-monitor the Power Control System, such that failure of the ability to monitor the energy flow or failure of the ability to control the output of the DER, results in halting the production of energy by the DER or the separation of the DER system from parallel operation with the Distribution System.
- The configuration and settings governing the power control limiting functions shall be password protected, accessible only by qualified personnel.
- The power to the control system must be battery backed up and if the power to the control is not available the DER system must be blocked from operation.



### 11.3. Documentation

DER applications that include a power control system must also include additional information specific to the power control system. At minimum, the following information should be supplied to Nodak Electric regarding the power control system.

- Make and model of the power control system.
- Electrical schematic of the monitoring for the power control system.
- User manual for the control of the power control system.
- Response time to modifying the output of the DER, in response to a large step change in the local electrical loads.
- Description of the operating reason and modes (shown in the user manual) which will be utilized.
- Description of how other operating modes (shown in the user manual) are being restricted so they are not able to be enabled.
- Other information which is useful to help Nodak Electric understand the power control system.

Prior to final interconnection, the Interconnection Customer shall supply updated power control system documentation to Nodak Electric.

### 11.4. Inadvertant Export

Inadvertent export is the flow of energy, in excess of a defined amount, through the PCC and back onto the Distribution System. Inadvertent export can have a detrimental effect on the Distribution System, damaging equipment or causing a power outage.

Inadvertent export shall be limited to 10% of the nameplate DER rating or 100kW, whichever is less, for a maximum of 30 seconds. The cumulative amount of inadvertent exported energy from the Local EPS to the Distribution System, across the PCC, in any billing month shall be less than the on-site aggregated DER Nameplate Rating(s) multiplied by one hour. The power control system shall be designed to limit inadvertent export to these levels, unless mutually agreed to between the Interconnection Customer and Nodak Electric and documented in the Operating and Maintenance Requirements section of the Interconnection Agreement.

Any amount of inadvertent export of real power across the PCC lasting longer than 30 seconds for any single event shall result in the disconnection of the DER system from the Distribution System within two seconds of exceeding the 30 second duration limit.

### 11.5. Power Control Limited Capacity

For rotating machines or inverter-based DER systems larger than 20kW in Nameplate Rating, the DER Operator shall submit details of the proposed Power Control limiting method for maximum capacity limiting, along with settings, if applicable. Nodak Electric shall review and either approve the proposed Power Control method and settings or provide a response as to why the method does not provide adequate control. The DER system should use the IEEE 1547 configuration settings as the preferred means of Power Control limited capacity.

## 11.6. Power Control Limited Export and Limited Import

Power Control limited export and Power Control limited import can provide means of meeting the requirements of specific Nodak Electric's tariffs or other technical requirements. The DER Operator shall obtain approval from Nodak Electric for any Power Control limiting system which is implemented. Power Control limiting for inverter-based DER systems with a Nameplate Rating of 20kW or less shall use a certified control system tested to UL 1741. For these smaller systems, the DER Owner shall submit proposed settings to Nodak Electric for review and approval. For DER systems with a Nameplate Rating larger than 20kW using a certified control system tested to UL 1741, the DER Operator shall provide test results showing the magnitude and duration of power import or export.

The Power Control limited export and import may be applied using a UL 1741 certified Power Control System to limit import or export. Additionally, Power Control limited export may be applied using the IEEE 1547 *maximum active power* parameter to limit export in the management settings<sup>7</sup> in cases where the RPA is at the PCC. The *maximum active power* parameter in the DER management information shall be used as a static limit when employed for limiting export. Similarly, the Power Control System import or export limit shall be a static limit when employed for limiting export or limiting import.

The current approved standards-based approaches for Power Control limiting have a maximum open loop response time limit of 30 seconds for limiting inadvertent active power exchange with the Distribution System. Active power exchange may occur for a period of time within this 30 second limit due to Local EPS conditions such as block load changes. Reactive power exchange between the DER, Local EPS and the Distribution System may occur during normal operations, but level and amount of this exchange shall be in accordance with applicable agreements.

The configuration and settings governing the Power Control limiting functions shall be password protected, accessible only by qualified personnel, or protected by other means which have been approved by Nodak Electric.

## 12. Interoperability

### 12.1. Overview

Depending on the method of interconnection and the size of the DER system, there are different interoperability requirements. Information from the DER is needed for Nodak Electric to perform fault analysis, load flow and system reliability analysis. Remote monitoring and remote control maybe required depending on the size of the DER, type of interconnection and the mode of operation. In general, Table 6 displays the need for remote monitoring and remote control of the DER by size. DER with ESS that do not export may have different monitoring and control requirements. Specific remote monitoring and control

---

<sup>7</sup> IEEE 1547 Section 4.6.2 allows for an active power limit to be set as an export limit when the RPA is the PCC. The parameter is found in Table 40 of IEEE 1547 Section 10.6.12.

requirements will be identified in the Operating and Maintenance Requirements of the Interconnection Agreement.

Table 6 – Monitoring and Control Requirements for DER Systems

Monitoring and Control Requirements for DER Systems		
DER System Nameplate Capacity	DER Remote Monitoring	DER Remote Control
0 – 40kW	None Required	None Required
40 – 1,000kW	SCADA Monitoring Likely	Remote control via Nodak Electric’s SCADA Possible
> 1,000kW	SCADA Monitoring Required	Remote control via Nodak Electric’s SCADA Likely

### 12.2. Monitoring, Control and Information Exchange

When information exchange through the Local DER Communication Interface is required by Nodak Electric, the IEEE 1547 interoperability parameters shall be available for use. Nodak Electric shall have read access to all parameters in the nameplate information and monitoring information. Nodak Electric shall have read and write access to all parameters in configuration information and management information. Nodak Electric may choose to use a subset of the available parameters in order to meet operating objectives of safe, reliable, and quality electric service. Writing of information by Nodak Electric through the Local DER Communication Interface, shall follow agreements governing Nodak Electric control of the DER operating state control modes and parameters.

When the Local DER Communication Interface is required by the Nodak Electric, the utility shall have access to read and write parameters shown in the sub clauses associated with IEEE 1547, Section 4.6 – *Control capability requirements* – including capability to disable permit to service; capability to limit active power; and execution of mode and parameter changes.

### 12.3. Sales to Parties Other Than Nodak Electric

The Technical Requirements do not address the metering, monitoring and control requirements for a DER system whose energy sales are to a party other than Nodak Electric. For energy sales to a party other than Nodak Electric, the monitoring and control requirement will be identified in the Operating and Maintenance Requirements section of the Interconnection Agreement.

### 12.4. Level of Communication Required

When SCADA monitor or SCADA monitoring and control is required, the DER Owner is responsible for the cost to provide the communications to Nodak Electric’s control center. For DER system larger than 1,000kW requiring monitoring and control, Nodak Electric will install the communication channel. The Interconnection Customer is responsible for Nodak Electric’s cost of the communication channel.

The communication channel shall meet the following requirements:

- Available via a VPN tunnel,
- Able to support a polling rate of once every 10 seconds,

- Encrypted,
- Utilize DNP3.0 protocol, and
- Include a battery backup system that can last for a minimum of 8 hours during an outage.

## 12.5. Level of Monitoring and Control Required

The actual list of status, control and analog points required to be monitored and controlled by Nodak Electric are to be defined in the Operating and Maintenance Requirements section of the Interconnection Agreement. In general, the minimum points that will be required for DER systems 1,000kW and greater are:

- Status Points
  - Lockout relay status
  - High voltage alarm
  - Low voltage alarm
  - Relay failure alarm (for each protective relay)
  - Interconnection breaker(s) status (open/close)
  - DC battery charger alarm
  - General trouble alarm
- Control Points
  - Remote control of interconnection breaker(s)
  - Ability to curtail the output of the DER to a specific level
  - Ability to remotely change and/or monitor modes of operations that are active
- Analog Values
  - Phase voltage (phase to ground)
  - DER phase current (amp) output
  - Frequency
  - Power Factor (including leading/lagging)
  - DC voltage of backup battery system
  - Current Total Harmonic Distortion
  - Voltage Total Harmonic Distortion
  - Three-phase real (kW) and reactive (kVA) power flow of each DER unit

## 12.6. Cyber Security

In general, all physical, network and local DER communication interface security protections should be identified by the Interconnection Customer and approved by Nodak Electric. Specific security requirements are listed in Sections 12.6.1, 12.6.2 and 12.6.3.

### 12.6.1. DER Physical and Front Panel Security

The Interconnection Customer shall maintain physical security for the DER equipment and all communication interfaces at the DER site. All configuration settings for the DER system shall be password protected to allow access only to qualified personnel. Other physical security protections shall be identified by the Interconnection Customer and approved by Nodak Electric.

#### 12.6.2. DER Network Security

Dependent on the DER interconnection, additional network security may apply. If needed, the additional requirements will be identified in the Operating and Maintenance Requirements section of the Interconnection Agreement.

#### 12.6.3. Local DER Communication Interface Security

Dependent on the DER interconnection, additional local DER communication interface security may apply. If needed, the additional requirements will be identified in the Operating and Maintenance Requirements section of the Interconnection Agreement.

### 13. Energy Storage Systems

#### 13.1. Control Modes

Changes in ESS Control Modes to a mode that was not proposed and reviewed during the interconnection process can result in tariff violations or cause adverse technical impacts to the Distribution System. ESS Control Modes may not necessarily be considered a Material Modification; however, the Interconnection Customer shall notify Nodak Electric of an unapproved ESS Control Mode prior to the change being implemented. Nodak Electric shall discuss with the Interconnection Customer the need, or lack thereof, to review the proposed ESS Control Mode for safety, power quality or reliability reasons.

IEEE 1547 states that a functional software or firmware change may result in another verification process at that time of interconnection and interoperability requirements. The IEEE 1547 standard, and other national standards and certifications, are currently silent on requirements relating to ESS Control Mode. Until such time national standards are established, the Nodak Electric's Operations may require:

- i. Documenting at the time of application the ESS Control Modes being applied for by the ESS owner.
- ii. Documenting at the time of application the charge/discharge profile(s) or use case(s) intended to be utilized by the ESS owner.
- iii. The ESS Control Mode(s) reviewed and approved should be documented in an Operating Agreement. The Operating Agreement should also list the ESS Control Mode(s) that is being utilized. Nodak Electric shall be notified of changes to ESS Control Mode(s).
- iv. A method of ESS Control Modes security shall be furnished by the DER Operator to assure only ESS Control Modes applied for and reviewed by Nodak Electric are used. The security may be in the form of password protection of the functions.
- v. Nodak Electric may initiate verification of the ESS operation after the interconnection is complete if information is available indicating the ESS is not functioning as designed or approved.

#### 13.2. Grid Support Functions

The Technical Requirements will not address technical issues that may arise with grid support functions. The use of an ESS to provide grid support functions is not allowed.

### 13.3. Common Modes of Operation

Energy storage systems are still an evolving technology with different use cases and modes of operation. Multiple control modes may be utilized by the Interconnection Customer. When applying for interconnection with the Distribution System, the DER Applicant should indicate what control modes of operation are being utilized. The Interconnection Customer must not change the control mode of the ESS without notification to Nodak Electric. Nodak Electric only studies the ESS under the indicated operation mode(s) listed on the original interconnection application.

### 13.4. ESS Load Aspects

The load aspects of ESS are not in scope of the IEEE 1547 standard, but reviewing the load aspects in conjunction with generation aspects is crucial to evaluating impacts to the Distribution System and leads to a more efficient review of the overall system. Impacts from ESS may contribute to requirements and mitigations, including but not limited to: electrical component upgrades; information exchange through use of the Local DER Communication Interface; or protection and control system upgrades.

Any Nodak Electric's operating characteristics requirements for ESS charging operations shall not be more restrictive than the operating characteristics requirements of other comparable loads, to the extent practical or upon mutual agreement. The maximum charge rate of the ESS shall be included in materials submitted to Nodak Electric during the technical review portion of the interconnection process.

### 13.5. Enter Service

After any sustained electrical outage, the ESS shall be configured to not immediately initiate recharging of the ESS. Per the IEEE 1547 standards the ESS shall wait a minimum of five (5) minutes after the Distribution System is reenergized and provides a stable voltage, before initiating recharging of the ESS.

It is preferable to delay any recharging of the ESS for a minimum of ten (10) minutes after reenergization of the Distribution System, to allow the distribution system to fully stabilize and reduce the possibility of additional electrical demand caused by the recharging of the ESS to overload the distribution system.

To help reduce the possibility of step voltage issues and other distribution system issues, it is preferable to have the ESS control system ramp up the recharging level from 0-100% over a five-minute time period upon entering service.

### 13.6. Modification to Control Modes

ESS Control Modes may not necessarily be considered a Material Modification; however, the Interconnection Customer shall notify Nodak Electric of an unapproved ESS Control Mode prior to the change being implemented. Nodak Electric shall discuss with the Interconnection Customer the need, or lack thereof, to review the proposed ESS Control Mode for safety, power quality or reliability reasons.

The Interconnection Customer can inform Nodak Electric of a change in ESS control mode by emailing Nodak Electric's DER Coordinator. The ESS should not be operated in the new control mode without approval from Nodak Electric.

## 14. Intentional Islanding

As an alternative to cease to energize and trip in response to voltage or frequency disturbances or unintentional island detection, a Local EPS island may be formed. When DER meets the criteria of Section Response to Faults and Open Phase Conditions, a Local EPS island may be formed rather than ride-through for voltage or frequency disturbances. If DER does not meet the criteria of Section 6, the transition to the Local EPS island shall meet the rapid voltage change requirements of IEEE 1547. When paralleling a Local EPS island to the Distribution System, the Enter Service and Synchronization requirements of Section Enter Service shall be met.

DER systems designated by authority having jurisdiction as emergency, legally required, or critical operations power systems providing backup power to hospitals, fire stations or other emergency facilities as defined by applicable industry code, shall be exempt from this section and may Cease to Energize and Trip or separate from the Distribution System without limitation.

Scheduled intentional Local EPS islands are allowed in accordance with IEEE 1547 Section 8.2.2 and applicable agreements.

Intentional Distribution System islands shall only be allowed upon mutual agreement between Nodak Electric and DER Operator.

## 15. Test and Verification Requirements <sup>h</sup>

Prior to a DER system's initial interconnection or operation in parallel with the Distribution System, Nodak Electric may require verification and testing of the DER interconnection. Nodak Electric's Technical Requirement document is expected to be reviewed to understand the interconnection testing requirements.

The process associated with design, approval and execution of test and verification procedures follows:

- Nodak Electric shall define the characteristics of tests that are required by applying standards and best practices.
- The RPA shall be specified in the one-line diagram submitted to Nodak Electric with the Interconnection Application. The DER Operator shall denote the RPA where the test and verification feature shall be applied in the written test procedure, if required.
- When required by Nodak Electric, the DER Operator shall provide written test procedure to Nodak Electric for review.
- The testing and verification procedures shall be reviewed and approved by a Professional Engineer for non-certified systems or for certified systems greater than 250kW AC.
- Nodak Electric shall provide written feedback to the DER Operator, if written test procedures are required, indicating the determination if the test and verification meets applicable requirements. Prior to witness testing, Nodak Electric may require the DER Operator to attest the DER system is ready for testing.



- Nodak Electric and the DER Operator shall arrange for qualified personnel to perform the test procedures. Each entity shall operate their own equipment.
- Nodak Electric may arrange personnel to witness the test procedures being performed by the DER Operator.
- Nodak Electric may evaluate the DER as-built installation, including as outlined in IEEE 1547.1, during this site visit to verify that the installation meets interconnection and interoperability requirements.

The applicable DER evaluation, commissioning tests and verifications, shall be performed per IEEE 1547 and IEEE 1547.1. See Appendix E for additional details.

### 15.1. Certified DER Systems

It is understood that DER systems that are certified by UL 1741 / IEEE 1547 have already undergone scrutiny and testing. As such the testing required to commissioning these systems is designed to recognize the previous testing and focus on integration with the Distribution System and the final installed DER. The following testing requirements shall be met prior to parallel operation with the Distribution System:

- i. Verifications of certified equipment make and model.
- ii. Verification of system wiring.
- iii. For new installations, verification of meter with Nodak Electric's AMI system.
- iv. Verification of anti-islanding.
- v. Verification of grounding.

### 15.2. Non-Certified DER Systems

For non-certified systems, it is the Interconnection Customer's responsibility to provide a final design for approval and to install the protective measures required by Nodak Electric. Mutually agreed upon exception may, at times, be necessary and desirable. Prior to Commissioning of the DER, the Interconnection Customer shall provide the design with proof that it shall not connect or close into a de-energized Distribution System. The Interconnection Customer shall obtain written approval of the design as installed prior to completing the commissioning testing of the DER.

### 15.3. Documentation

All interconnection-related protection systems shall be periodically tested and maintained, by the Interconnection Customer, at intervals specified by the manufacturer or system integrator. These intervals shall not exceed five years. Periodic test reports and a log of inspections shall be maintained, by the Interconnection Customer and made available to Nodak Electric upon request. Nodak Electric shall be notified prior to the period testing of the protective systems, so that Nodak Electric personnel may witness the testing, if so desired.

#### 15.3.1. Battery Documentation

Any system that depends upon a battery for trip/protection power shall be checked and logged once per month for proper voltage. Once every four years the

battery(ies) must be either replaced or a discharge test performed. Longer intervals are possible using the “station class batteries” and Nodak Electric approval.

#### 15.4. Failure Protocol

In the event that a DER fails testing and verification, the DER Operator shall resolve any out-of-compliance items and provide updated documentation to Nodak Electric regarding the changes made. The Interconnection Customer shall re-schedule the onsite testing with Nodak Electric and provide a revised testing procedure, if necessary.

#### 15.5. Reverification and Periodic Test

The DER Operator shall notify Nodak Electric prior to any of the following events occurring:

- Protection functions are being adjusted after the initial commissioning process.
- Functional software or firmware changes are being made on the DER.
- Any hardware component of the DER is being modified in the field or is being replaced or repaired with parts that are not substitutive components compliant with this standard.
- Protection settings are being changed after factory testing.

Prior to modifications to the DER triggering reverification, the DER Operator shall notify Nodak Electric’s Interconnection Coordinator. Any of the above events may be cause for requiring reverification of the interconnection and interoperability requirements, per IEEE 1547 clause 11.2.6.

Nodak Electric may specify the frequency or time intervals for periodic testing consistent with Nodak Electric’s policies or manufacturer requirements.

#### 15.6. Pre-Energization Testing – Interconnection Customer

The following testing shall be performed by the Interconnection Customer. Nodak Electric has the right to witness all field tests and review all records prior to allowing the system to be made ready for normal operation. Nodak Electric shall be notified with adequate lead time of witness testing.

- 1) Grounding shall be verified to ensure that it complies with this specification, the NESC and the NEC.
- 2) CTs (Current Transformers) and VTs (Voltage Transformers) used for monitoring and protection, shall be tested to ensure correct polarity, ratio and wiring.
- 3) CTs shall be visually inspected to ensure that all grounding and shorting connections have been removed where required.
- 4) Breaker / Switch tests – Verify that the breaker or switch cannot be operated with interlocks in place or that the breaker or switch cannot be automatically operated when in manual mode. (The intent of this test is to ensure that the breaker or switch controls are operating properly).

- 5) Relay tests – All protective relays shall be calibrated and tested to ensure the correct operation of the protective element. Documentation of all relay calibration tests and settings shall be furnished to Nodak Electric.
- 6) Trip checks – Protective relays shall be functionally tested to ensure the correct operation of the complete system. Functional testing requires that the complete system is operated by the injection of currents and/or voltage to trigger the relay elements and prove that the relay element trips the required breaker, lockout or provides the correct signal to the next control element. Trip circuit shall be proven through the entire scheme (including breaker trip).
- 7) Remote Control, SCADA and Remote Monitoring tests – All remote-control functions and remote monitoring points shall be verified operational. For some monitoring points it may not be possible to verify analog values prior to energization. Where appropriate, those points may be verified during the energization process.
- 8) Phase tests – the Interconnection Customer shall work with Nodak Electric to complete the phase test to ensure proper phase rotation of the DER system and wiring.
- 9) Synchronizing test – The following tests shall be done across an open switch or racked out breaker. The switch or breaker shall be in a position that it is incapable of closing between the Generation System and the Distribution System for this test. This test shall demonstrate that at the moment of the paralleling-device closure, the frequency, voltage and phase angle are within the required ranges, stated in IEEE 1547. This test shall also demonstrate that if any of the parameters are outside of the ranges stated; the paralleling device shall not close. For inverter-based interconnected systems this test may not be required unless the inverter creates fundamental voltages before the paralleling device is closed.

## 15.7. Energization Testing Criteria

Some tests are unable to be performed prior to interconnection with the Distribution System. Once the pre-energization tests are completed, the DER shall be integrated and the energization tests shall be performed. For larger and more complex DER systems the Interconnection Customer and Nodak Electric should work together to develop the required testing procedure. Final proposed testing procedure shall be submitted to Nodak Electric prior to energization testing. The testing procedure should include the location, method of operation and verification for each step. At minimum, the testing procedure shall include the steps listed in Section 15.7.1 and 15.7.2.

### 15.7.1. Installation Verification

Prior to the anti-islanding testing, the DER system shall have the following verified:

- 1) That there is continuous, unescorted site access to the Distribution System equipment and Utility DER AC Disconnect is available. Site access means drivable and keyless access.

- 2) The DER installation matches the submitted one-line diagram that was approved by Nodak Electric.
- 3) There is proper labeling of disconnect switches, meters and placards, if necessary.
- 4) That the Interconnection Customer will verify the settings and firmware of the inverters, protective devices, power control systems and other hardware and software components comply with Nodak Electric's Technical Requirements, operating agreements and match the previously approved settings.

#### 15.7.2. Anti-Island Testing

For DER systems that operate in parallel with the Distribution System, the anti-islanding test procedure shall, at minimum, contain the following steps:

- 1) The DER system shall be placed into normal operations.
- 2) The DER system shall be verified it is energized and generating.
- 3) The Distribution System source shall be removed from the DER system. For multi-phase systems, the Distribution System source shall be removed by one individual phase at a time.
- 4) The DER system shall be verified that it is either separate from the Distribution System together with the local load or the DER system shall stop operating.
- 5) The DER system shall be reconnected to the Distribution System. The DER generation shall not parallel with the Distribution System for a period less than 5 minutes.

For each step, the testing procedure shall identify which device shall be operated to complete the step. In verification step, the testing procedure shall identify the point of measurement.

#### 15.7.3. Additional Onsite Testing

Depending on the complexity of the DER system, additional energization tests may be required. Examples of additional tests include phase testing, control mode verification, SCADA and communication verification. These additional tests shall be listed in the Interconnection Customer's submitted testing procedure as applicable.

### 15.8. Modification to Existing DER

Any time the interface hardware or software, including protective relaying and generation control systems are replaced and/or modified, Nodak Electric shall be notified. This notification shall, if possible, be adequate so the Distribution System personnel can be involved in the planning for the modification and/or witness the verification testing. Verification testing shall be completed on the replaced and/or modified equipment and

systems. The involvement of the Distribution System personnel will depend upon the complexity of the DER system and the component being replaced and/or modified.

## **16. Sample Documentation for Tier I Applications <sup>h</sup>**

### **16.1 Introduction**

The Interconnection Customer shall maintain a system one-line diagram, site diagram and testing procedure with latest results.

All documentation shall include the following:

- Interconnection Customer's Name
- Interconnection Agent's Name, Address, and Phone Number
- Date and revision

### **16.2 One-line Diagram**

The one-line diagram shall include, but not limited to, the following information:

- Applicant Name
- Application ID
- Installer name and contact information
- Address where DER system will be installed
- Correct electrical position of all equipment, including but not limited to: Panels, Inverter, DC and AC disconnects.
- Distance between equipment
- Labeling found on equipment
- Total Aggregated AC nameplate rating of DER
- DER protection elements

The one-line diagram shall be signed and stamped by a North Dakota Professional Electrical Engineer if the DER is larger than 20kW and uncertified or larger than 250kW and certified.

Figure 1 - Example Simplified One-Line Diagram

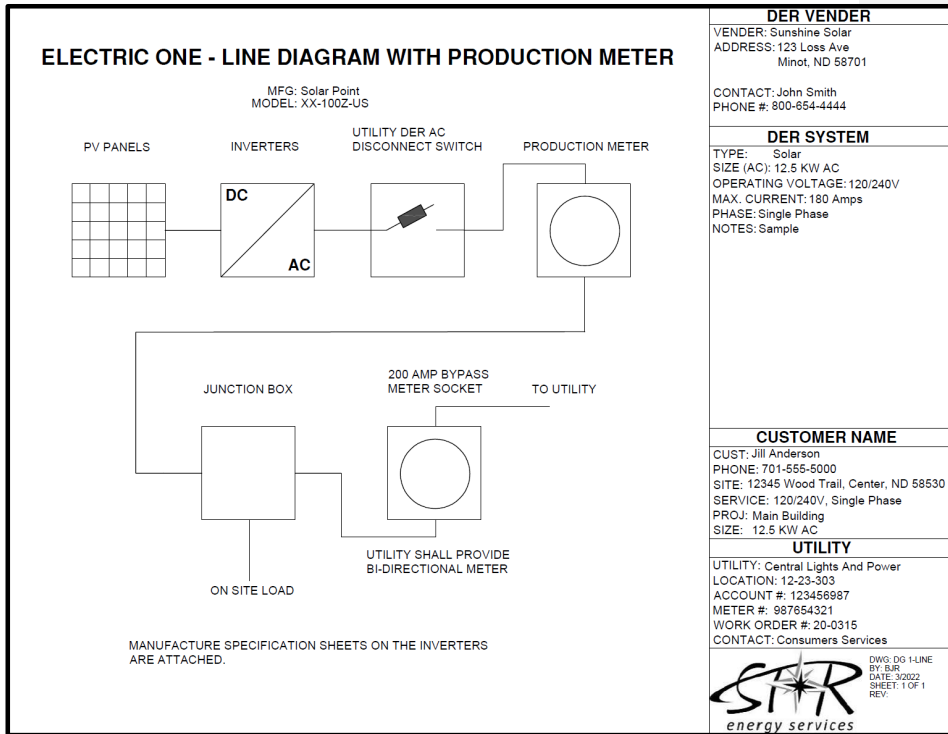

### 16.3 Site Diagram

Site Diagram shall include the following:

- Shall be to scale
- Location of DER
- Location of meter(s)
- Location of Utility AC disconnect
- Location of PCC/RPA/PoC
- Location of underground/overhead electrical wires
  - If underground, shall include any easements/right of ways

Figure 2 - Sample Tier I Site Diagram

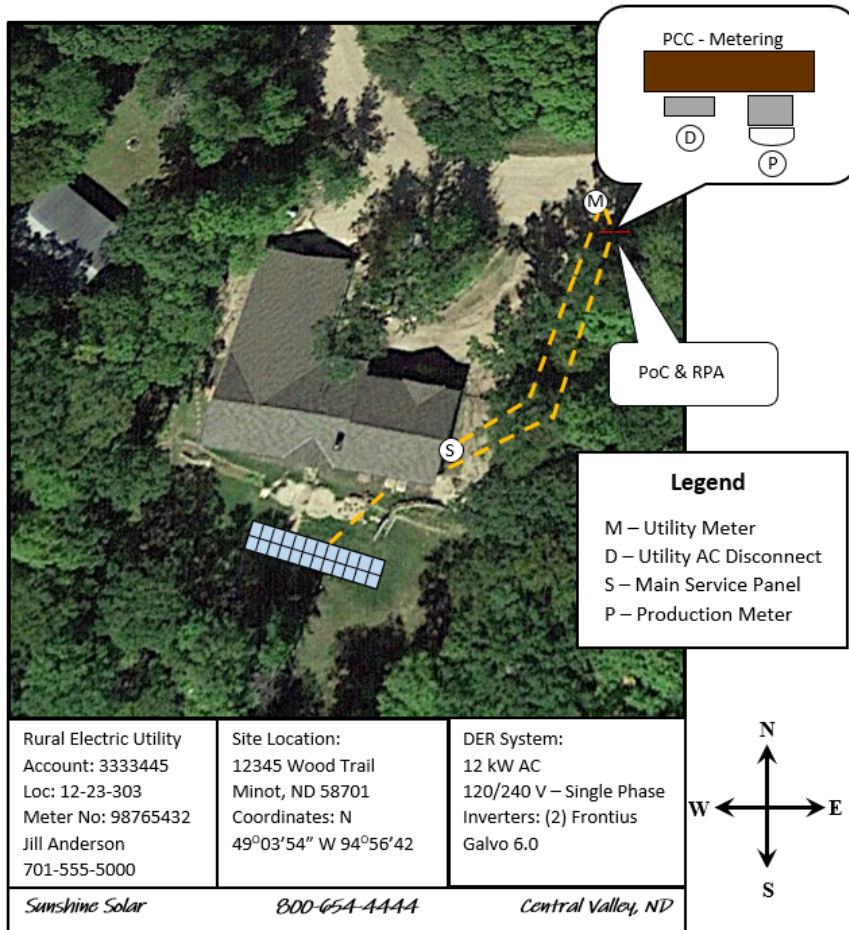

## 16.4 Testing Procedure

### General Process for Tier I Testing Procedures

- Verify installation matches design evaluation
  - Verify inverter model matches application
  - Verify certified inverter
  - Verify electrical inspection sticker
  - Verify correct labeling / signage
  - Verify Utility DER AC Disconnect Switch is lockable and has visual open
  - Verify DER system installation matches application one-line
  - Verification of operational and protection settings
  - Verify metering and Utility DER AC Disconnect Switch are accessible by Nodak Electric
- Field Testing
  - On-off test
  - Open phase testing (if applicable for multiphase systems)

An example of a Tier I DER testing procedure is found in Appendix B.



## 17. References

The standards, codes, certification, guides and recommended practices listed in this section are active as of the publication of this document. These standards, codes, certifications, guides and recommended practices may be superseded, withdrawn, or additional applicable revisions may become available after the publication of this document. Later revisions of the technical references listed below may be available and supersede the versions referenced in this document. At the time an interconnection application is submitted, Nodak Electric and the DER Operator shall use the most recent applicable technical reference. Application of industry standards, codes, certifications, guides and recommended practices shall be consistent with the standard governing body's manuals, policies, and procedures.

IEC TR 61000-3-7:2008, Electromagnetic compatibility (EMC) - Part 3-7: Limits - Assessment of emission limits for the connection of fluctuating installations to MV, HV and EHV power systems.

IEC 61000-4-3:2006+A1:2007+A2:2010, Electromagnetic compatibility (EMC) - Part 4-3: Testing and measurement techniques - Radiated, radio-frequency, electromagnetic field immunity test.

IEC 61000-4-5:2014+A1:2017, Electromagnetic compatibility (EMC) - Part 4-5: Testing and measurement techniques – Surge immunity test.

IEEE Std 1547-2018, IEEE Standard for Interconnection and Interoperability of Distributed Energy Resources with Associated Electric Power Systems Interfaces

IEEE Std 1547.1, IEEE Standard Conformance Test Procedures for Equipment Interconnecting Distributed Resources with Electric Power Systems

IEEE Std 1547.2, Application Guide for IEEE 1547 Standard for Interconnecting Distributed Resources with Electric Power Systems

IEEE Std 1547.3-2007, Guide for Monitoring Information Exchange and Control of DR Interconnected with Electric Power Systems

IEEE Std 1547.4-2011, IEEE Guide for Design, Operation, and Integration of Distributed Resource Island System with Electric Power Systems

IEEE Std 1547.6-2011, IEEE Recommended Practice for Interconnecting Distributed Resources with Electric Power Systems Distribution Secondary Networks

IEEE Std 1547.7-2013, IEEE Guide for Conducting Distribution Impact Studies for Distributed Resource Interconnection

IEEE Std 519-2014, IEEE Recommended Practices and Requirements for Harmonic Control in Electric Power Systems

IEEE Std 1453-2015, IEEE Recommended Practice for the Analysis of Fluctuating Installation on Power Systems

IEEE Std 1453.1-2012 (Adoption of IEC/TR 61000-3-7:2008) - IEEE Guide--Adoption of IEC/TR 61000-3-7:2008, Electromagnetic compatibility (EMC)--Limits--Assessment of emission limits for the connection of fluctuating installations to MV, HV and EHV power systems

IEEE Std C37.90-2005, IEEE Standard for Relay Systems Associated with Electric Power Apparatus

IEEE Std C37.90.1-2012, IEEE Standard Surge Withstand Capability (SEC) Tests for Protective Relays and Relay Systems Associated with Electric Power Apparatus

IEEE Std C37.90.2-2004, IEEE Standard Withstand Capability of Relay Systems to Radiated Electromagnetic Interference from Transceivers

IEEE C37.95-2014, IEEE Guide for Protective Relaying of Utility-Consumer Interconnections

IEEE Std C50.12-2005, IEEE Standard for Salient-Pole 50 Hz and 60 Hz Synchronous Generators and Generator/Motors for Hydraulic Turbine Applications Rated 5 MVA and Above.

IEEE Std C50.13-2014, IEEE Standard for Cylindrical-Rotor 50 Hz and 60 Hz Synchronous Generators Rated 10 MVA and Above.

IEEE Std C62.41.2-2002, IEEE Recommended Practice on Characterization of Surges in Low Voltage (1000V and Less) AC Power Circuits

IEEE Std C62.42-2016, Guide for the Application of Component Surge-Protective Devices for Use in Low-Voltage [Equal to or Less than 1000 V (ac) Or 1200 V (dc)] Circuits

IEEE Std C62.45-2002, IEEE Recommended Practice on Surge Testing for Equipment Connected to Low-Voltage (1000 V and Less) AC Power Circuits.

IEEE Std C62.92.2-2017, IEEE Guide for the Application of Neutral Grounding in Electric Utility Systems, Part II – Grounding of Synchronous Generator Systems

IEEE Std C62.92.6-2017, IEEE Guide for the Application of Neutral Grounding in Electric Utility Systems, Part VI

IEEE Std 32-1972 (Reaff 1990), IEEE Standard Requirements, Terminology, and Test Procedure for Neutral Grounding Devices

IEEE Std 141-1993, IEEE Recommended Practice for Electric Power Distribution for Industrial Plants – Red Book

IEEE Std 142-2007, IEEE Recommended Practice for Grounding of Industrial and Commercial Power Systems – Green Book

IEEE Std 242-2001, Recommended Practice for Protection and Coordination of Industrial and Commercial Power Systems

IEEE Std 446-1995, Recommended Practice for Emergency and Standby Power Systems for Industrial and Commercial Applications

IEEE Std 2030-2011, Guide for Smart Grid Interoperability of Energy Technology and Information Technology Operation with the Electric Power System (EPS), End-Use Applications, and Loads

IEEE Std 2030.5-2013, IEEE Adoption of Smart Energy Profile 2.0 Application Protocol Standard.

IEEE Std 1815-2012, IEEE Standard for Electric Power Systems Communications-Distributed Network Protocol (DNP3)

ANSI C84.1-2016, Electric Power Systems and Equipment – Voltage Ratings (60 Hertz)

UL 1741, Inverters, Converters, and Controllers for use in Independent Power Systems

ANSI C2-2007, National Electrical Safety Code, Published by the Institute of Electrical and Electronics Engineers, Inc.

NFPA 70, National Electrical Code, Published by the National Fire Protection Association

IEC 61850-7-420:2009, Communication networks and systems for power utility automation - Part 7-420: Basic communication structure - Distributed energy resources logical nodes

IEC 62351-12:2016, Power systems management and associated information exchange - Data and communications security - Part 12: Resilience and security recommendations for power systems with distributed energy resources (DER) cyber-physical systems

## 18. Appendix A – Example Diagrams

Figure 3 - Example of Typical One-line Diagram of Solar DER Less than 20kW

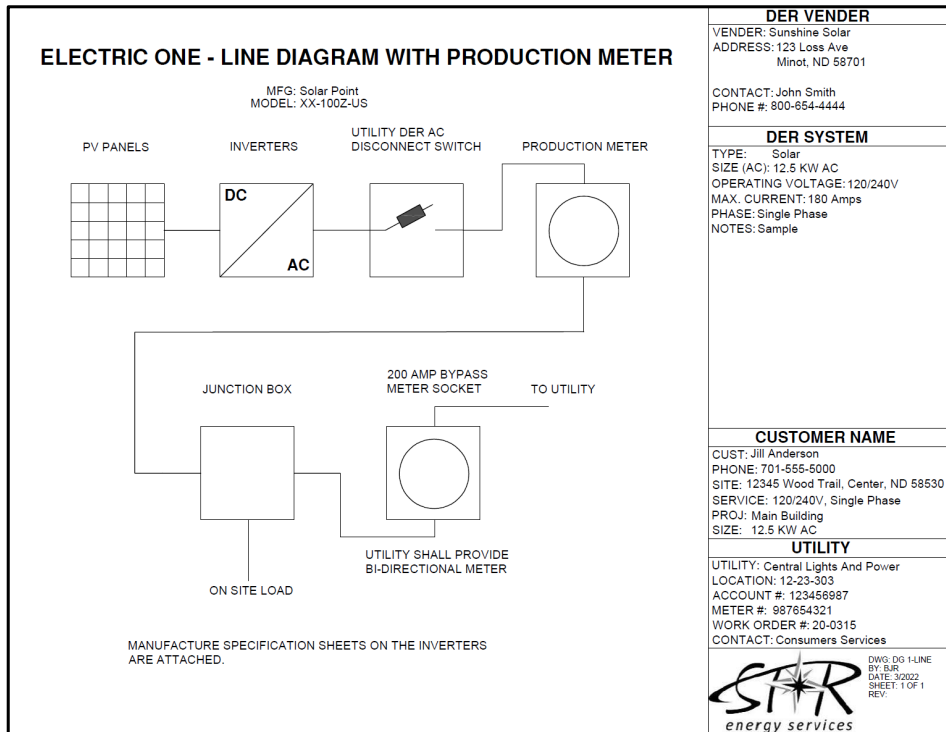

Figure 4 - Example One-Line of Solar and ESS with a Common Inverter Less than 20kW

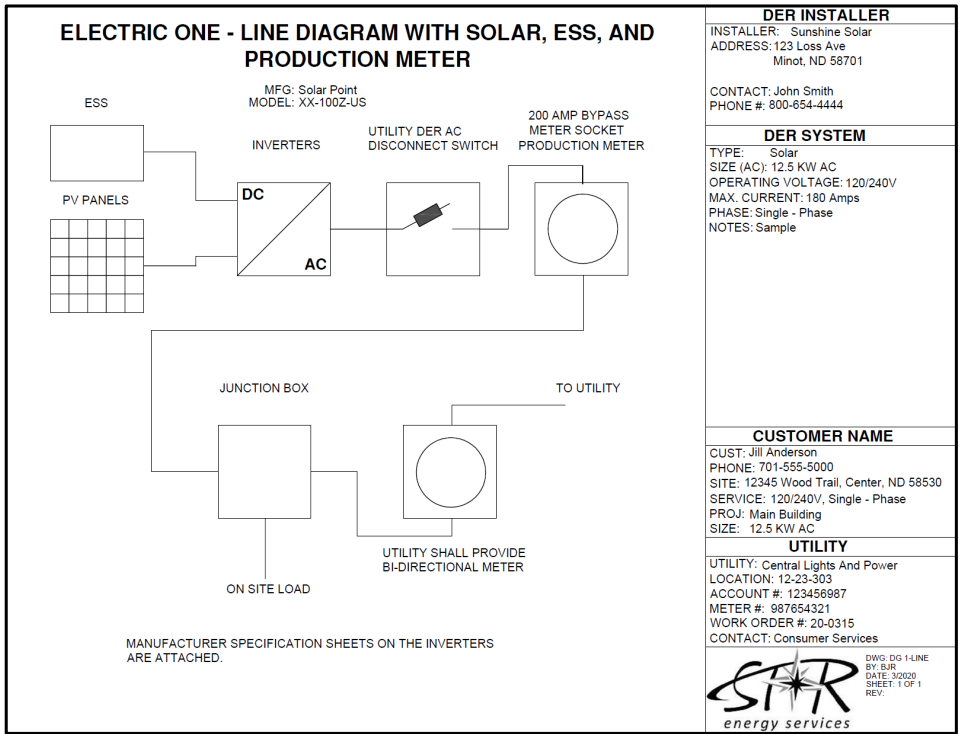

Figure 5 - Example One-Line of Solar and ESS with Separate Inverters Less than 20kW

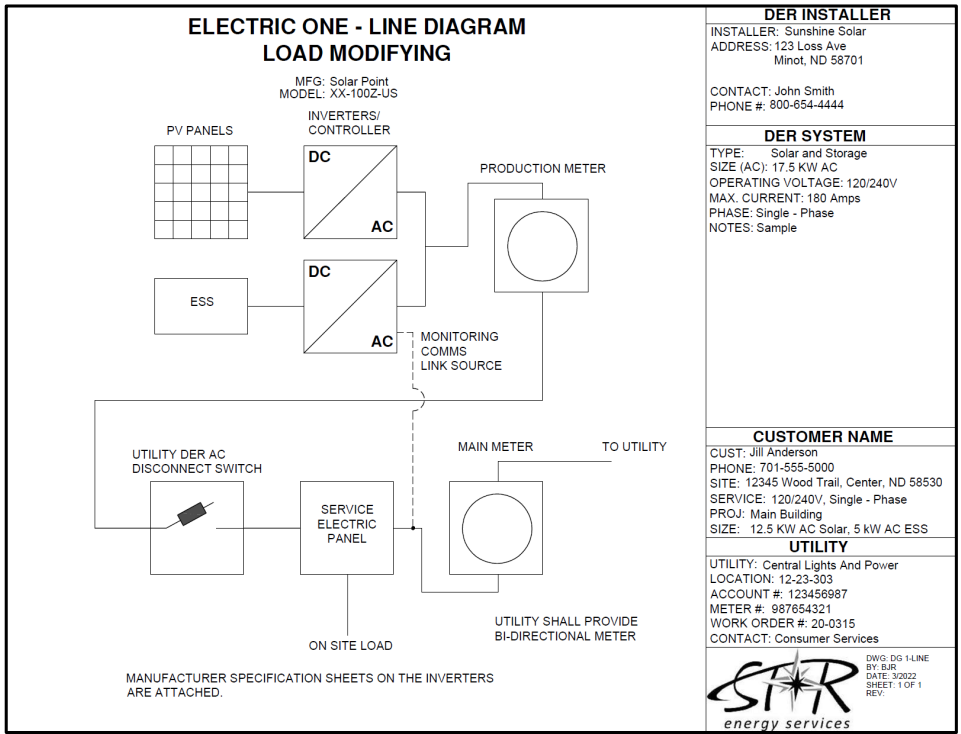
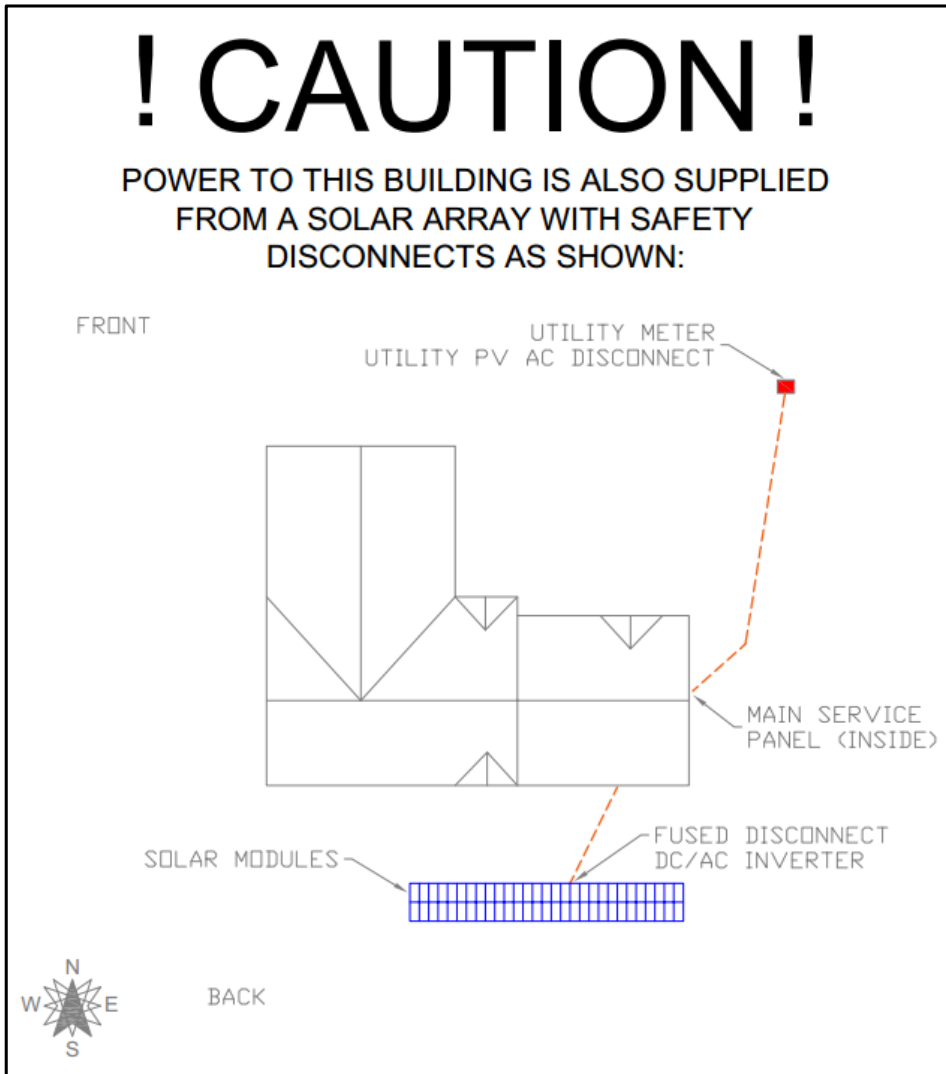

Figure 6 - Example Placard



## 19. Appendix B – Example DER Testing Procedure

DER ENERGIZATION PROCEDURE			
<b>Application ID</b>		<b>DER System Size (kW AC)</b>	
<b>Interconnection Customer Name</b>		<b>DER System Type</b>	
<b>Area EPS Operator</b>		<b>Testing Date</b>	

**Visual Verifications**

YES	NO	
		Verify inverter model matches application
		Verify inverter is certified (UL 1741)
		Verify electrical inspection
		Verify correct labeling/signage
		Verify the Utility DER AC Disconnect Switch is lockable and has visual open
		Verify DER system installation matches submitted one-line drawing
		Verify metering and Utility DER AC Disconnect Switch are accessible by Area EPS Operator

**Anti-Island Field Test**

**Step 1.** The DER system shall be started in parallel with the distribution system.

**Step 2.** Disconnect the DER from Area EPS by opening the Utility DER AC Disconnect Switch.

YES	NO	
		Production from DER system ceased to operate (no current flowing towards the Area EPS)
		or
		DER system separated from the local load. (A turbine may still spin but no power is being produced to the load.)

**Step 3.** Reconnect the DER system to the Area EPS by closing the Utility DER AC Disconnect Switch.

YES	NO	
		The DER system did not parallel with Area EPS or begin to serve to local EPS load for at least 5 minutes once Utility DER AC Disconnect Switch was closed.

**Step 4.** Disconnect the DER from Area EPS by requesting Area EPS Operator to disconnect the Area EPS at PCC.

YES	NO	
		Production from DER system ceased to operate (no current flowing towards the Area EPS)
		or
		DER system separated from the local load. (A turbine may still spin but no power is being produced to the load.)

Energization Testing Procedure 1



### Open Phase Testing: Multi-phase DER Systems Only

**Step 5.** Disconnect the DER from Area EPS by requesting Area EPS Operator to disconnect the Area EPS at PCC one phase at a time. (If possible, this test can be performed by the Interconnection Customer on the Local EPS at the PoC if only one DER unit.)

YES	NO	
		Phase A: Production from DER system ceased to operate (no current flowing towards the Area EPS)
		Phase B: Production from DER system ceased to operate (no current flowing towards the Area EPS)
		Phase C: Production from DER system ceased to operate (no current flowing towards the Area EPS)

Energization Test Result:	PASS	FAIL
Notes:		
Documented by:		
Testing Attendees:		

### Verification of Operational and Protection Settings

*If Notice of Completion was not provided, installer to certify inverter settings.*

I certify that the inverters were programmed so:

- Operating Mode is set to Constant Power Factor with the power factor set to 0.98 absorbing
- The Frequency Abnormal Response is set to IEEE 1547-2003 ranges
- The Voltage Abnormal Response is set to IEEE 1547-2003 ranges
- Dynamic Voltage Support and Volt-Watt is not active (no ride through)

Signature:

#### IEEE 1547-2003 Voltage Abnormal Response

Shall Trip Function	Default Setting	
	Clearing time (s)	Voltage (per unit of nominal voltage)
UV2	0.16	0.50
UV1	2.0	0.88
OV1	1.0	1.10
OV2	0.16	1.20

#### IEEE 1547-2003 Frequency Abnormal Response

Shall Trip Function	Default Setting	
	Clearing time (s)	Frequency (Hz)
UF1	0.16	59.3
OF1	0.16	60.5

## 20. Appendix C – Types of Interconnections

The way the DER system is connected to and disconnected from the Distribution System can vary. Most transfer systems normally operate using one of the following five methods of transferring the load from the Distribution System to the DER system.

If a transfer system is installed which has a user accessible selection of several transfer modes, the transfer mode that has the greatest protection requirements will establish the protection requirements for that transfer system.

### **Open Transition (Break-Before-Make) Interconnection**

With this interconnection, the load to be supplied from the DER is first disconnected from the Distribution System and then connected to the DER. This transfer can be relatively quick, but voltage and frequency excursions are to be expected during transfer. Computer equipment and other sensitive equipment will shut down and reset. The transfer switch typically consists of a standard UL approved transfer switch with mechanical interlocks between the two source contactors that drop the Distribution System source before the DER is connected to supply the load.

- 1) To qualify as an Open Transition switch and the limited protective requirements, mechanical interlocks are required between the two source contacts. This is required to ensure that one of the contacts is always open and the generating DER is never operated in parallel with the Distribution System. If the mechanical interlock is not present, the protection requirements are as if the switch is a closed transition switch.
- 2) As a practical point of application, this type of transfer switch is typically used for loads less than 500kW. This is due to possible voltage flicker problems created on the Distribution System, when the load is removed from or returned to the Distribution System source. Depending upon the Distribution System's stiffness, this level may be larger or smaller than the 500-kW level.
- 3) Figure 7 on the following page provides a typical one-line of this type of installation.

Figure 7 – Open Transition (Break-Before-Make) Interconnection

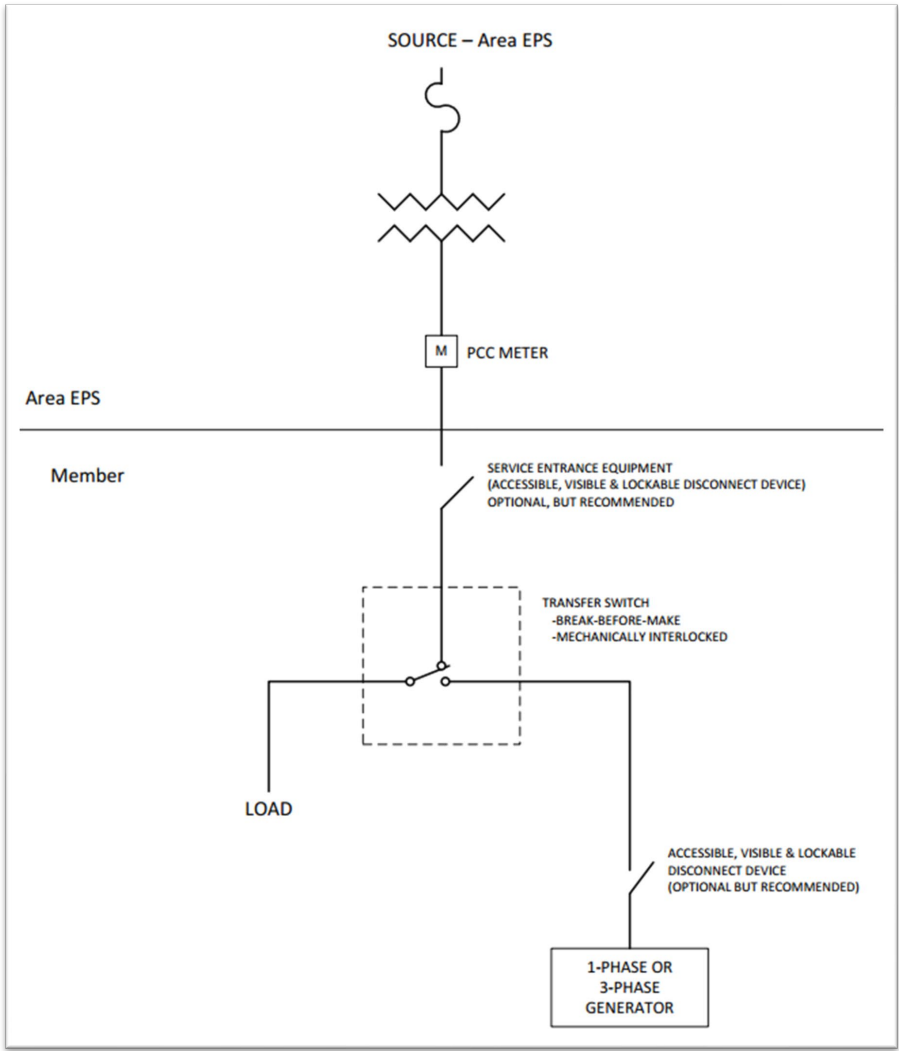

Note: Break-Before-Make Automatic Transfer Switch shall be mechanically interlocked.

### **Quick Open Transition (Break-Before-Make) Interconnection**

For a Quick Open Transition, the load to be supplied from the DER is first disconnected from the Distribution System and then connected to the DER, similar to the open transition. However, this transition is typically much faster (under 500 ms) than the conventional open transition transfer operation. Voltage and frequency excursions will still occur, but some computer equipment and other sensitive equipment will typically not be affected with a properly designed system. The transfer switch consists of a standard UL approved transfer switch, with mechanical interlocks between the two source contacts that drop the Distribution System source before the DER is connected to supply the load.

- 1) Mechanical interlocks are required between the two source contacts to ensure that one of the contacts is always open. If the mechanical interlock is not present, the protection requirements are as if the switch is a closed transition switch.
- 2) As a practical point of application this type of transfer switch is typically used for loads less than 500kW. This is due to possible voltage flicker problems created on the Distribution System, when the load is removed from or returned to the Distribution System source. Depending upon the Distribution System's stiffness this level may be larger or smaller than the 500-kW level.
- 3) Figure 7 on the previous page provides a typical one-line of this type of installation and shows the required protective elements.

### **Limited Quick Closed Transition (Make-Before-Break) Interconnection**

For Limited Quick Closed Transition, the DER is synchronized with the Distribution System prior to the transfer occurring. The transfer switch then parallels with the Distribution System for a short time (100 ms or less) and then the DER and load is disconnected from the Distribution System. This transfer is less disruptive than the Quick Open Transition because it allows the DER a brief time to pick up the load before the support of the Distribution System is lost. With this type of transfer, the load is always being supplied by the Distribution System or the DER.

- 1) As a practical point of application this type of transfer switch is typically used for loads less than 500kW. This is due to possible voltage flicker problems created on the Distribution System, when the load is removed from or returned to the Distribution System source. Depending upon the Distribution System's stiffness this level may be larger or smaller than the 500-kW level.
- 2) Figure 8 on the following page provides a typical one-line of this type of installation and shows the required protective elements. The closed transition switch must include a separate parallel time limit relay, which is not part of the generation control PLC and trips the generation from the system for a failure of the transfer switch and/or the transfer switch controls.

Figure 8 – Limited Quick Closed Transition (Make-Before-Break) Interconnection

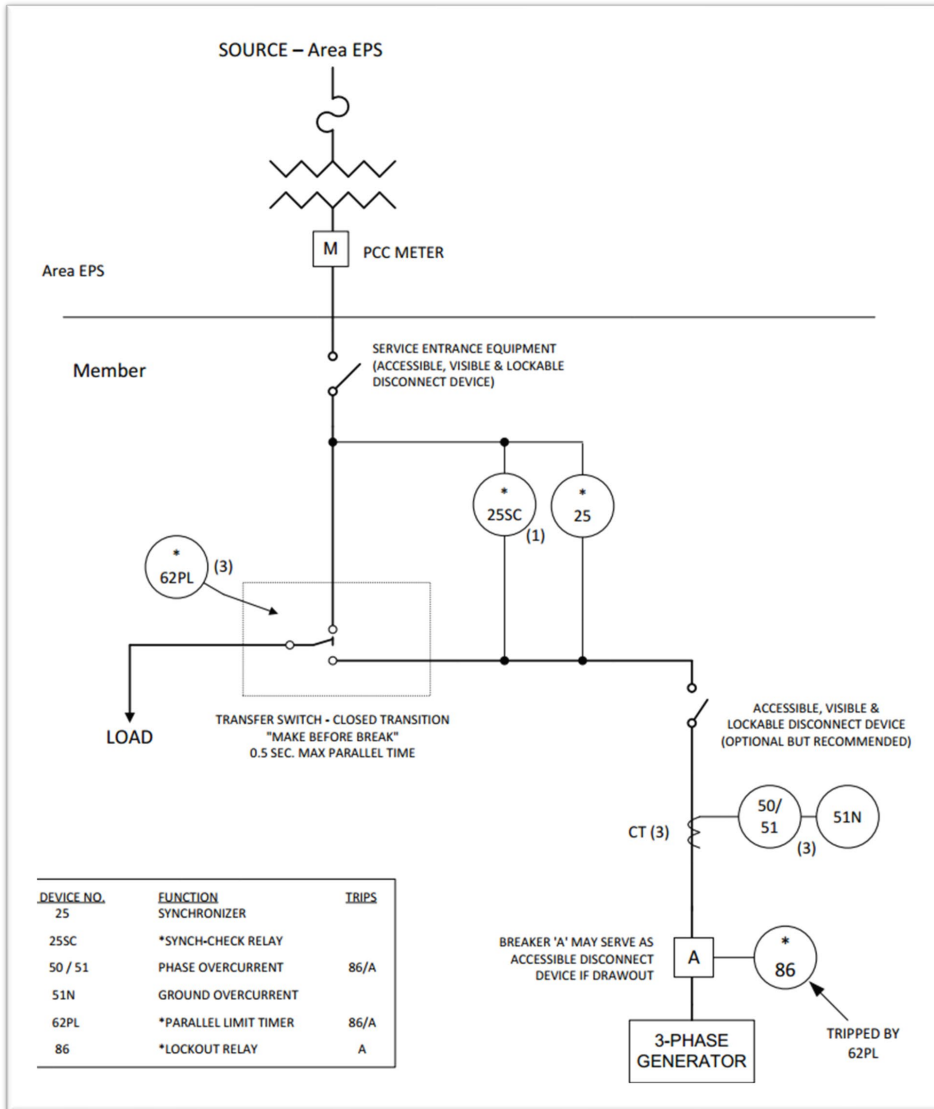

Notes: (1) (2) (3) indicates number of phases to be monitored.  
 \* Indicates minimum required protection. Other relays shown are recommended for generator protection.

### **Closed Transition Interconnection – With Limited Parallel Operation**

For this type of interconnection, the DER is paralleled with the Distribution System for a limited amount of time, less than 2 minutes, to gradually transfer the load from the Distribution System to the generating DER system. This minimizes the voltage and frequency problems, by softly loading and unloading the DER.

- 1) The maximum parallel operation shall be controlled, via a parallel timing limit relay (62PL). This parallel time limit relay shall be a separate relay and not part of the generation control PLC.
- 2) Protective Relaying is required as described in Section 21 of this document.
- 3) Figure 9 on the following page provides a typical one-line diagram of this type of installation and show the required protective elements.

Figure 9 – Closed Transition Limited Parallel Interconnection

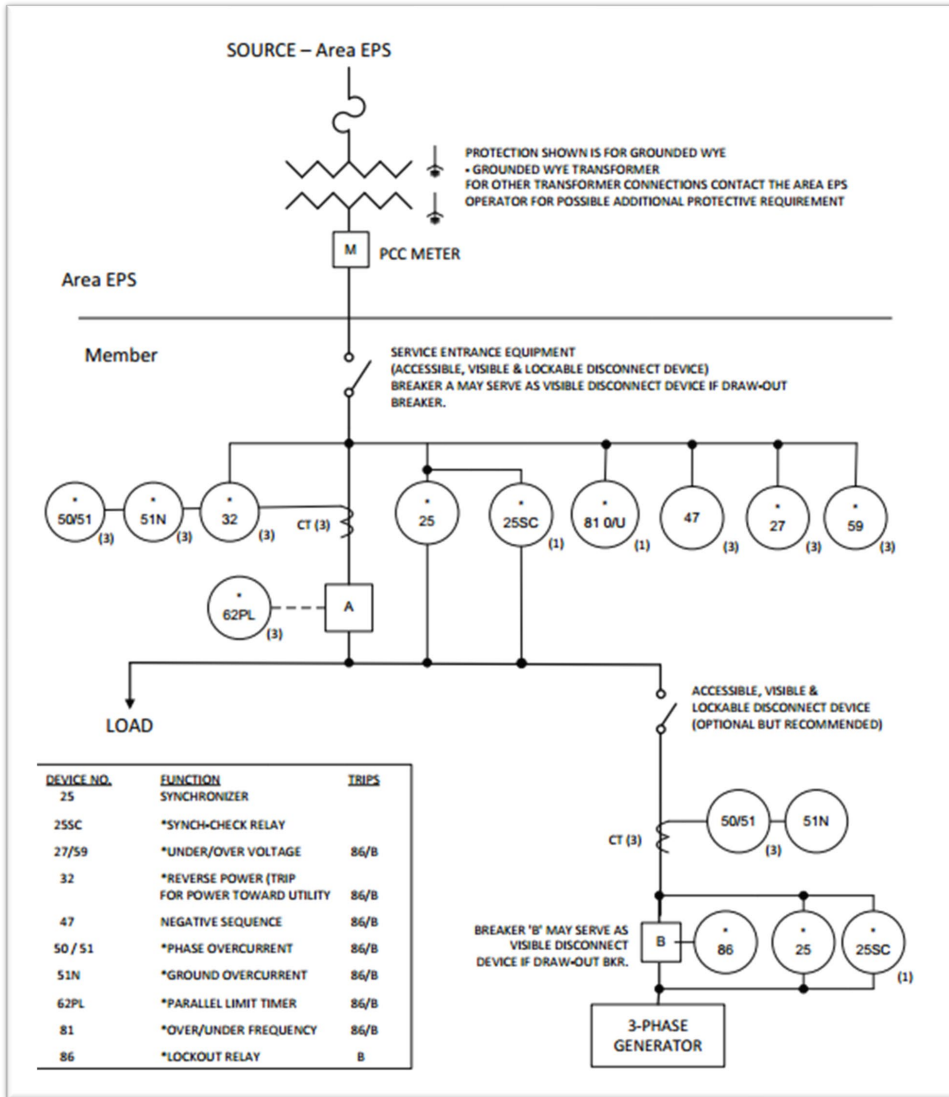

Notes: (1) (2) (3) indicates number of phases to be monitored.  
 \* Indicates minimum required protection. Other relays shown are recommended for generator protection.

#### **Soft Loading Transfer Switch – With Extended Parallel Operation**

The DER is paralleled with the Distribution System in continuous operation. Special design, coordination and agreements are required before any extended parallel operation will be permitted. The Distribution System interconnection study will identify the issues involved.

- 1) Any anticipated use in the extended parallel mode requires special agreements and special protection coordination.
- 2) Protective Relaying is required as described in Section 21 of this document.
- 3) Figure 10 on the following page provides a typical one-line for this type of interconnection. It must be emphasized that this is a typical installation only and final installations may vary from the examples shown due to transformer connections, breaker configuration, etc.



Figure 10 – Extended Parallel Interconnection

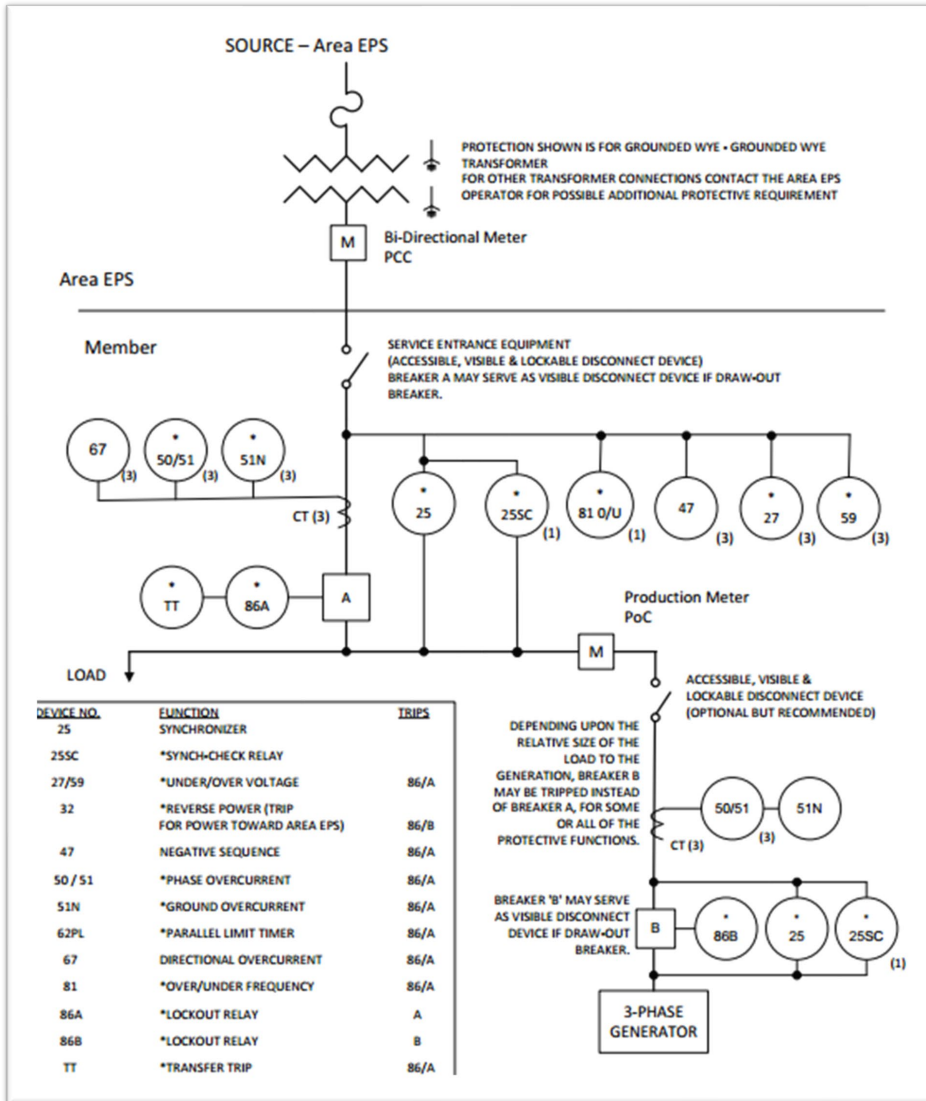

Notes: (1) (2) (3) indicates number of phases to be monitored.  
 \* Indicates minimum required protection. Other relays shown are recommended for generator protection.  
 TT is not required for Generators less than 250kW

### **Inverter Connection**

An Inverter Connection is a continuous parallel connection between the DER and Distribution System. Small generating DER systems may utilize inverters to interface to the Distribution System. Solar, wind and fuel cells are some examples of DER which typically use inverters to connect to the Distribution System. The design of such inverters shall either contain all necessary protection to prevent unintentional islanding, or the Interconnection Customer shall install conventional protection to affect the same protection. All required protective elements for a soft-loading transfer switch apply to an inverter connection. Figure 11 on the following page shows a typical inverter interconnection.

- 1) **Inverter Certification** – Prior to installation, the inverter shall be Type-Certified for interconnection to the electrical power system. The certification will confirm its anti-islanding protection and power quality related levels at the Point of Common Coupling. Also, utility compatibility, electric shock hazard and fire safety are approved through UL listing of the model. Once this Type Certification is completed for that specific model, additional design review of the inverter should not be necessary by Nodak Electric.
- 2) For three-phase operation, the inverter control must also be able to detect and separate for the loss of one phase. Larger inverters will still require custom protection settings, which must be calculated and designed to be compatible with the specific Distribution System being interconnected with.
- 3) A visible disconnect is required for safely isolating the DER when connecting with an inverter. The inverter shall not be used as a safety isolation device.
- 4) When banks of inverter systems are installed at one location, a design review by Nodak Electric must be performed to determine any additional protection systems, metering or other needs. The issues will be identified by Nodak Electric during the interconnection process.

Figure 11 – Inverter-based Interconnection

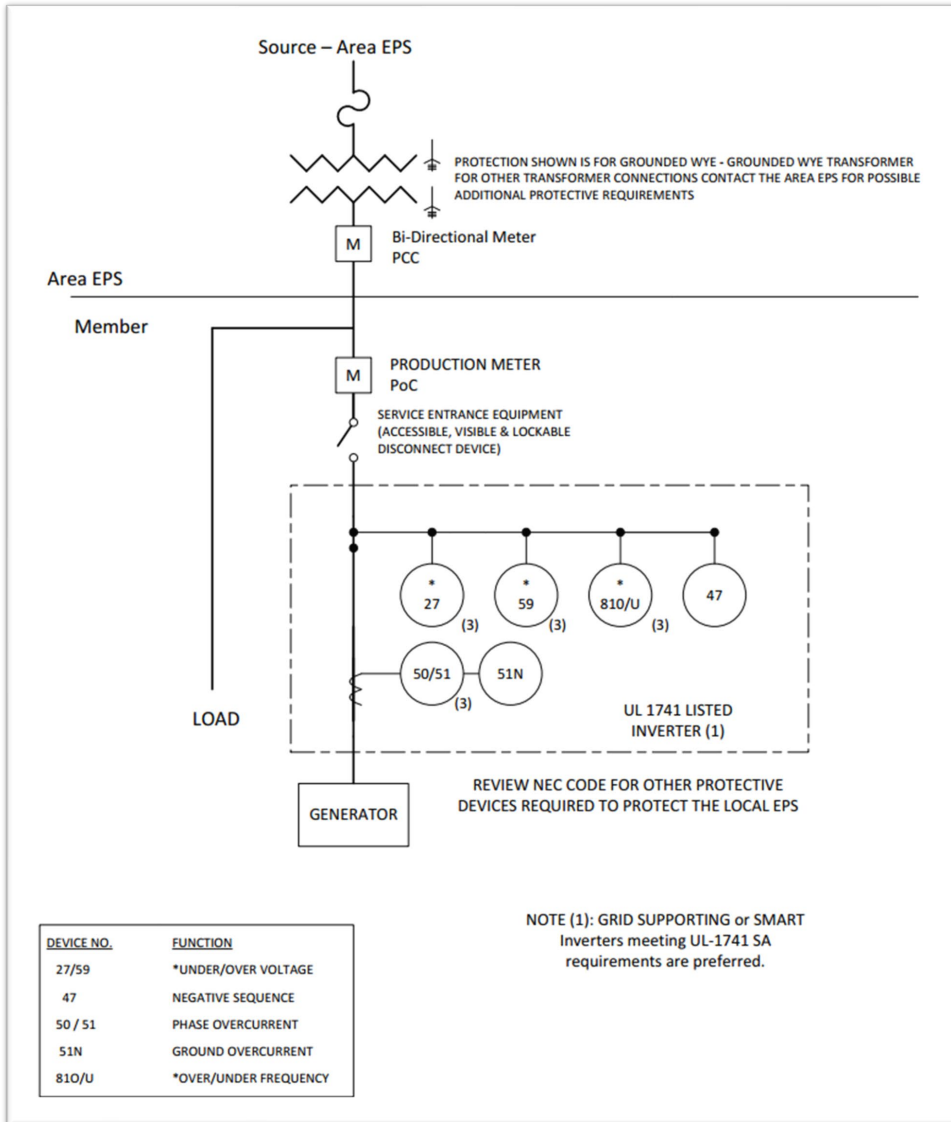

Notes: (1) (2) (3) indicates number of phases to be monitored.  
\* Indicates minimum required protection. Other relays shown are recommended for generator protection.

## 21. Appendix D – Relay Functions

Non-Certified installations, depending on the interconnection configuration, are required to provide the appropriate relay function listed in this section. The interconnection types in Appendix C will specify which relay function may be applicable.

Over-current relay (IEEE Device 50/51 or 50/51V) shall operate to trip the protecting breaker at a level to ensure protection of the equipment and at a speed to allow proper coordination with other protective devices. For example, the over-current relay monitoring the interconnection breaker shall operate fast enough for a fault on the customer's equipment, so that no protective devices will operate on the Distribution System. 51V is a voltage restrained or controlled over-current relay and may be required to provide proper coordination with the Distribution System.

Directional Over-Current Relay (IEEE Device 67) This element uses the phase relationship of the voltage and current to determine direction of the fault.

Over-Voltage Relay (IEEE Device 59) shall operate to trip the DER per the requirements of IEEE 1547. See table in Section 6.2.

Under-Voltage Relay (IEEE Device 27) shall operate to trip the DER per the requirements of IEEE 1547. See table in Section 6.2.

Over-Frequency Relay (IEEE Device 81O) shall operate to trip the DER off-line per the requirements of IEEE 1547. See table in Section 6.3.

Under-Frequency Relay (IEEE Device 81U) shall operate to trip the DER off-line per the requirements of IEEE 1547. See table in Section 6.3.

Synch Check Relay (IEEE Device 25 / 25SC) The Distribution System will provide the reference frequency of 60 Hz. The DER control system must be used to match this reference. The protective relaying in the interconnection system will be expected to maintain the frequency of the output of the DER.

Phase Sequence or Phase Balance Detection (IEEE Device 47) Provides protection for rotating equipment from the damaging effects of excessive negative sequence voltage resulting from a phase failure, phase unbalance and reversed phase sequence. This element helps the DER sense loss of source issues on the Distribution System.

Reverse Power Relays (IEEE Device 32) (power flowing from the DER to the Distribution System) shall operate to trip the DER off-line for a power flow to the system with a maximum time delay of 2.0 seconds.

Lockout Relay (IEEE Device 86) is a mechanically locking device which is wired into the close circuit of a breaker or switch and when tripped will prevent any close signal from closing that device. This relay requires that a person manually resets the lockout relay before that device can be reclosed. These relays are used to ensure that a de-energized system is not reenergized by automatic control action and prevents a failed control from auto-reclosing an open breaker or switch.

Transfer Trip – All DERs are required to disconnect from the Distribution System when the Distribution System is disconnected from its source, to avoid unintentional islanding. A transfer trip system may be required to sense the loss of the Distribution System source for larger DERs which remain in parallel with the Distribution System. When the Distribution System source is lost, a signal is sent to the DER to

separate the DER from the Distribution System. The size and type of the DER and the capacity and minimum loading on the Distribution System circuit will dictate the need for transfer trip installation. The Distribution System interconnection process will identify the specific requirements for the proposed DER system.

If multiple Distribution System sources are available, or multiple points of sectionalizing exist on the Distribution System, more than one transfer trip system may be required. The Distribution System interconnection process will identify the specific requirements for the proposed DER system in this situation. For some installations, the alternate Distribution System source(s) may not be utilized except in rare occasions. In this situation, the Interconnection Customer may elect to have the DER locked out when the alternate source(s) are utilized, if agreeable to Nodak Electric.

Parallel Limit Timing Relay (IEEE Device 62PL) set at a maximum of 120 seconds for soft transfer installations and set no longer than 500 ms for closed transfer installations, shall trip the DER circuit breaker on limited parallel interconnection systems. Power for the 62PL relay must be independent of the transfer switch control power.

Minimum Input Relay (IEEE Device 37) is a setting within a digital relay that will trip the DER if the level of energy flow from the Distribution System goes below a set value. This protection system may be used by the DER to detect faults on the Distribution System. Minimum input relaying schemes must be set to trip immediately upon sensing under power levels and must coordinate with the Distribution System. Minimum input relaying is not allowed for DER systems which have the potential for inadvertent energy flow onto the Distribution System.

Table 7 – Summary of Relaying Requirements

Summary of Relaying Requirements								
Type of Interconnection	Over Current (50/51)	Voltage (27/59)	Frequency (81 O/U)	Reverse Power (32)	Lockout (86)	Parallel Limit Timer (62)	Synch Check (25)	Transfer Trip
Certified Inverter Connected < 250 kW	(1)	(1)	(1)	--	(1)	--	(1)	--
Certified Inverter Connected > 250 kW	Yes (2)	Yes (2)	Yes (2)	Yes (2)	Yes (2)	Yes (2)	Yes (2)	Yes (3)
Quick Open Transition Mechanically Interlocked	--	--	--	--	Yes	Yes	Yes	--
Limited Parallel Closed Transition	--	--	--	--	Yes	Yes	Yes	--
Soft Loading Limited Parallel Operations	Yes	Yes	Yes	Yes	Yes	Yes	Yes	--
Soft Loaded Extended Parallel < 250 kW	Yes	Yes	Yes	--	Yes	--	Yes	--
Soft Loaded Extended Parallel > 250 kW	Yes	Yes	Yes	--	Yes	--	Yes	Yes (3)
Extended Parallel > 250 kW	Yes	Yes	Yes	--	Yes	--	Yes	Yes (3)

Note (1): Function is part of a certified inverter.

Note (2): For inverter-based DER that is 250kW or larger, a breaker and relaying is required for interconnection with the Distribution System.

Note (3): Direct Transfer-Trip is required if the Distribution System determines the proposed DER cannot detect and trip for an Distribution System fault or loss of source supply to the Distribution System within an acceptable time-frame.

## 22. Appendix E – Full and Partial Conformance Testing and Verification

All DER used for interconnection with a Distribution System shall be tested to conform to IEEE 1547 interconnection requirements using IEEE 1547.1 conformance test procedures. One way a DER shall be considered as conforming to IEEE 1547 is if it has been submitted by a manufacturer, tested and listed by an Occupational Safety and Health Administration (OSHA) Nationally Recognized Testing Laboratory (NRTL) for continuous grid interactive operation in compliance with the applicable codes and standards and is determined to be fully compliant. DER equipment shall be tested to conform to the IEEE 1547 requirements and listed in accordance with an OSHA NRTL.

All inverter-based DER units shall be UL 1741 certified. Certified DER equipment that do not require a supplemental DER device to meet IEEE 1547 requirements at the Reference Point of Applicability and where the impedance between the PCC and PoC is less than 0.5% on the DER rated apparent power and voltage base shall be considered fully compliant. Partially compliant DER shall require further evaluation and possible testing. All DER systems shall meet the requirements of IEEE 1547 regardless of whether they are classified as fully or partially compliant.

IEEE 1547 introduces the concepts of Reference Point of Applicability, which is located at either the PoC or the PCC. The IEEE 1547 standard section 4.2 should be referenced to determine the RPA, as the RPA is the point at which testing and verification requirements apply.

Figure 12 details the test and verification required steps when the RPA is at the PoC for a fully compliant DER Unit or DER system as well as a partially compliant composite DER system. Fully compliant DER Unit(s) require *basic* design evaluation and commissioning tests. Partially compliant DER Unit(s) require *detailed* design evaluation. For example, a fully compliant DER Unit(s) with the RPA at the PoC is representative of a residential rooftop PV system. The DER Unit would be type tested by a NRTL resulting in a UL 1741 certification. IEEE 1547.1 details the Design Evaluation and Commissioning Test required for each of the combinations of fully and partially compliant DER with the RPA at the PoC and PCC.

Figure 12 - Test and Verification Required Steps for RPA at PoC

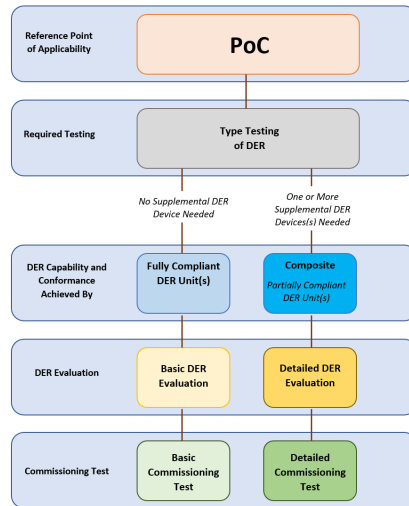
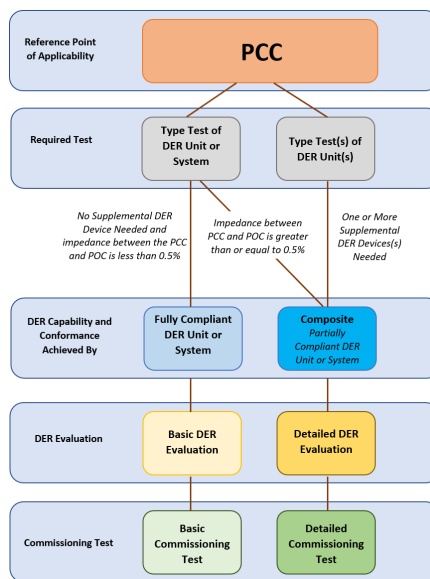

Figure 13 details test and verification requirements when the RPA is at the PCC. Requirements for fully compliant DER Unit or systems and partially compliant DER Unit or systems are addressed separately in terms of required testing and evaluation.

Figure 13 - Test and Verification Required Steps for RPA at PCC





## 23. Appendix F – IEEE 1547 – 2018 Settings

### 23.1. Availability of Certified Equipment

All requirements of the Technical Requirements are immediately applicable unless requiring equipment that conforms with IEEE 1547-2018 advanced functionalities. Nodak Electric cannot require the use of certified equipment that meets the requirements of IEEE 1547-2018 until such time the equipment is readily available. At such time certified equipment first becomes available, Nodak Electric and DER Owner may mutually agree to utilize the certified equipment and functionalities in conformance with the requirements of IEEE 1547-2018. Once certified equipment is readily available, Nodak Electric may require the following set of settings.

### 23.2. Performance Category Assignment

Based on IEEE 1547, Nodak Electric assigns normal performance categories - Category A and B, as shown in Section 23.2.1.

#### 23.2.1. Normal

Category A and B specify reactive power capability and voltage regulation performance requirements. Category B is intended for use where DER penetration is higher and where the DER power output is subject to frequent large variations. Category B encompasses all of Category A capabilities. Considering existing and future high penetration DER conditions, and the example decision tree in Annex B of IEEE 1547, the assignment of the category for reactive power capabilities and voltage regulation performance of DER for the Distribution System shall be as follows:

*Table 8 - Normal Performance Category Assignment*

Technology	Normal performance category
Inverter-based DER	Category B
Synchronous machine generation	Category A

The above assignment of Categories A and B is expected to cover the vast majority of interconnections. Any instances that do not fall within the above assignment shall be reviewed on a case-by-case basis, with Nodak Electric making determination<sup>8</sup> for requiring Category A or B.

#### 23.2.2. Abnormal

The abnormal performance category assignment should also consider a future level of DER penetration that could impact the TPS or BPS if not properly coordinated.

Until a decision is made by the Regional Transmission Operator within the region, all synchronous machine DER shall be assigned Category I and all inverter-based DER

<sup>8</sup> Nodak Electric should consider Annex B of IEEE 1547 when making these determinations on a case-by-case basis or in the Technical Requirements.

shall be assigned Category II. Any instances that do not fall within the above assignment shall be reviewed on a case-by-case basis, with Nodak Electric making determination for requiring Category I, II or III.

### 23.3. Use of Default Parameters

The DER shall use the IEEE 1547 default parameter settings for all capabilities and performance requirements of the applicable performance category unless otherwise specified by Nodak Electric’s Technical Requirements. In order to protect BPS and TPS reliability and to produce a response from DER that can be modeled, deviating from the default parameters for abnormal performance category settings should be a rare occurrence.

### 23.4. Alternative Abnormal Operating Performance Categories

Upon mutual agreement, provided no adverse effects are caused to the distribution system, TPS or BPS, exceptions may be made for Categories I, II and III if the DER technology is not able to meet the assignment outline in Section 23.2.2. This should be a rare occurrence. Should the DER technology readily exist to meet the stated assignments in Section 23.2.2, no exception shall be allowed.

### 23.5. Advanced Setting for Power Control and Tripping

#### 23.5.1. Voltage and Active Power Control (Volt-Watt)

The default settings<sup>9</sup> for Voltage and Active Power control are listed in Table 9.

*Table 9 - Voltage-Active Power Setting for Category A and Category B DER*

<b>Voltage-Active Power Parameters</b>	<b>Default Setting</b>
$V_1$	$1.06 V_n$
$P_1$	$P_{rated}$
$V_2$	$1.1 V_n$
$P_2$ (applicable to DER that can only generate active power)	The lesser of $0.2 P_{rated}$ or $P_{min}^a$
$P'_2$ (applicable to DER that can generate and absorb active power)	$0^b$
Open Loop Response Times	$10 s^c$

<sup>a</sup>  $P_{min}$  is the minimum active power output in p.u. of the DER rating.

<sup>b</sup>  $P'_{rated}$  is the maximum amount of active power that can be absorbed by the DER. ESS operating in the negative real power half plane, through charging, shall follow this curve as long as available energy storage capacity permits this operation.

<sup>c</sup> Any setting for the open loop response time of less than 3 seconds shall be approved by Nodak Electric with due consideration of system dynamic oscillatory behavior.

<sup>9</sup> The default IEEE 1547 volt-watt default setting will not begin curtailing real power until the voltage is beyond 1.06 per unit voltage, which is the upper end of the range of normal voltages allowed under ANSI C84.1.

### 23.5.2. Voltage Ride-Through and Tripping

The DER shall trip for any abnormal voltage. Table 10 and Table 11 list the maximum clearing time for the DER system upon the occurrence of abnormal voltage levels.

*Table 10 - DER Response (shall trip) to Abnormal Voltages for DER of Abnormal Operating Performance Category I*

Shall Trip – Category I		
Shall Trip Function	Default Setting	
	Clearing time(s)	Voltage (p.u. of nominal voltage)
UV2	0.16	0.45
UV1	2.0	0.7
OV1	2.0	1.10
OV2	0.16	1.20

*Table 11 - DER Response (shall trip) to Abnormal Voltages for DER of Abnormal Operating performance Category II*

Shall Trip – Category II		
Shall Trip Function	Default Setting	
	Clearing time(s)	Voltage (p.u. of nominal voltage)
UV2	0.16	0.45
UV1	10.0	0.70
OV1	2.0	1.10
OV2	0.16	1.20

### 23.5.3. Frequency Ride-Through and Tripping

The DER shall conform to the ride-through requirements for the applicable Abnormal Operating Performance Category. The IEEE 1547 default parameters shall be implemented by the DER Operator for the applicable performance category. The RTO may provide guidance on mandatory ride-through capabilities.

*Table 12 - DER Response (shall trip) to Abnormal Frequencies for DER of Abnormal Operating Performance Category I, Category II and Category III*

Shall Trip Function	Default Setting	
	Clearing time(s)	Frequency (Hz)
UF2	0.16	56.5
UF1	300.0	58.5
OF1	300.0	61.2
OF2	0.16	62.0

The DER shall conform to the Rate of Change of Frequency (ROCOF) ride-through requirements for the applicable Abnormal Operating Performance Categories. The

IEEE 1547 values shown in Table 13 shall be implemented by the DER Operator for the applicable performance category.

*Table 13 - Rate of Change Frequency (ROCOF) Ride-Through Requirements for DER of Abnormal Operating Performance Category I and Category II*

Category I	Category II
0.5 Hz/s	2.0 Hz/s

The DER shall conform to the frequency-drop requirements for the applicable Abnormal Operating Performance Categories. The IEEE 1547 values shown in Table 14 shall be implemented by the DER Operator for the applicable performance category.

*Table 14 - Rate of Change Frequency (ROCOF) Ride-Through Requirements for DER of Abnormal Operating Performance Category I and Category II*

Parameter	Default Settings <sup>a</sup>	
	Category I	Category II
$k_{OF}, k_{UF}$	0.05	0.05
$T_{\text{response (small signal) (s)}}$	5	5
$db_{OF}, db_{UF}$ (Hz)	0.036	0.036

#### 23.5.4. Exceptions

Tripping or intentional islanding as an alternative to ride-through is allowed in specific situations (such as when a large load is on premise) which may modify the DER response to abnormal conditions. Refer to IEEE 1547 Section 6.4.2.1 and 6.5.2.1 for additional details.

DER systems designated by authority having jurisdiction as emergency, legally required, or critical operations power systems providing backup power to hospitals, fire stations or other emergency facilities as defined by applicable industry code, shall be exempt from the ride-through requirements of this section.